

Attention!

**New heating boiler from Buderus.
Please observe assembly instructions.
Following completion of assembly
these instructions must be handed
over to the operator!**

Assembly and Maintenance Instructions

for the Buderus cast iron hot water boiler G_505
designed for oil or gas firing

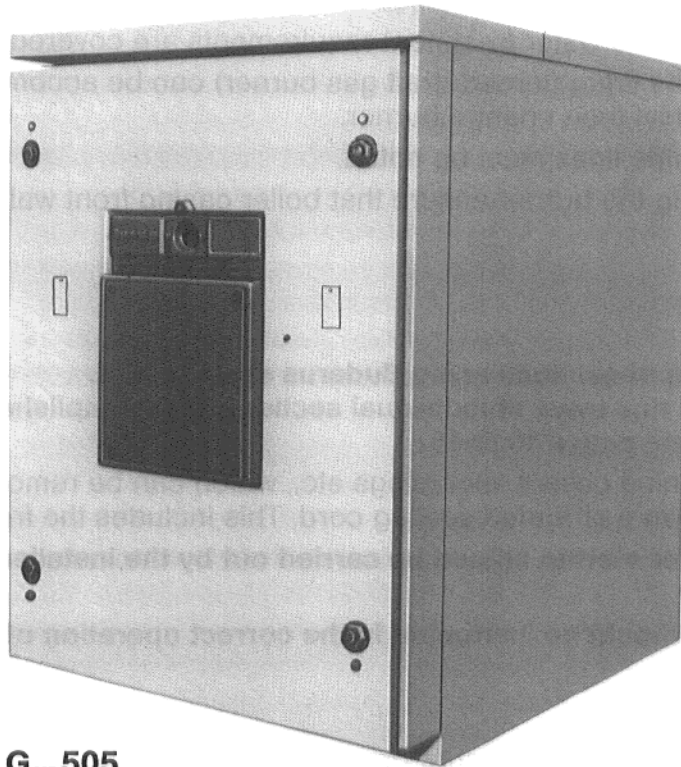

G_505
from 972 - 1599 MBTU/hr

Important points in connection with the application of the G_505 heating boiler

The instructions are intended for an experienced installer.

General (Safety Information)

The boiler is to be installed by a qualified contractor familiar with state and local regulations. All instructions and schematics are provided for reference purposes. Your state or local regulations may dictate that alternate procedures be used. All local codes take precedence over these installation instructions.

The hot water distribution system is not covered by this manual. It is important that the condition of the system be checked to insure safe operation at the time of installation.

Any leaks in the should be sealed, no matter how small. Continuous feeding of fresh water into any heating system can damage or block the water passages.

For assembling the burner to the boiler, follow the instructions of the burner manufacturer.

Utilization of the boiler:

Maximum supply temperature	240 °F
Maximum operating pressure	58 PSI

Information given on the name plate is important and should be noted.

Installation instructions for installers of heating systems should be noted.

The piping system must be installed and connected without stressing sections.

Make up water and water treatment requirements are covered in the operations manual.

Changing to gas firing (forced draft gas burner) can be accomplished quite simply. – Clean boiler thoroughly, then change burner.

Boiler room guide lines must be noted.

Before installing the burner ensure that boiler casing front wall has been installed.

Important!

Please note:

Simple jointing of sections using Buderus sealing cord.

The sealing of flue ways of individual sections is accomplished from one side only.

Please also note pages 10 to 15.

All doors, cleaning covers, mountings etc., which can be removed or opened for servicing are installed with a stranded sealing cord. This includes the front of the front section.

The initial boiler startup should be carried out by the installer or his designated specialist.

The operator should be instructed in the correct operation of the boiler (and the system)!

Oil and gas burners

Because of the low gas pressure drop thru the 505 boiler almost any commercial gas or oil burner can be used. Burners with reduced start up or two stage characteristics are preferred. To prevent condensation from forming inside the boiler full fire should match the nominal output of the boiler. Carbon monoxide (CO) readings should not exceed 400 ppm (= Parts per Million) in an air free sample.

Two stage burners should have the first stage set at a minimum of 60% of gross output. If a modulating burner is used then a minimum return water temperature of 122 °F must be ensured.

Modulating burners are not suitable if the boiler is equipped with the Buderus "Ecomatic" controller. The following standards and recommendations should be observed along with any local standards that apply.

- 1. Boiler foundation**
- 2. Technical data and boiler dimensions**
- 3. Assembly of boiler sections**
- 4. Hydraulic test**
- 5. Installation and tightening of fittings (Front section)**
- 6. Installation and tightening of fittings (Rear and connection section)**
- 7. Assembly of burner**
- 8. Assembly of boiler casing**
- 9. Cleaning and maintenance**
- 10. Control of the return temperature**

1

2

3

4

5

6

7

8

9

10

Delivery

Boiler supplied as loose sections (can be made up if requested)

Fittings in a packing case

Tie rods as a bundle

Boiler casing in a carton

If the boiler block is made up before delivery the spring sets have to be installed on site, after assembly and lining up of the boiler. One spring set per tie rod has to be fitted on the rear side of the boiler high and low level (see picture 16).

Tools and auxiliary materials

For the assembly of the boiler the following tools and auxiliary materials are required:

Complete set of Buderus pressure-drawing tools (2); drawing rods
(The special flange supplied is only intended for **repair work** and may only be used on the **upper boss of the rear section.**)

Hammer and also wooden mallet or rubber mallet

Half round file

Screw-driver (normal screw-driver and Phillips head driver)

Flat chisel, wedges, flat metal strips

Spanners SW 13, SW 19, SW 24 and SW 36

Red lead putty in linseed oil

Graphite paste (for nuts and bolts)

Steel wool, rags

Fine emery paper

Machine oil

Solvents (petrol or thinners)

Elastic sealing cord and stranded sealing cord

Spirit level, yard stick, chalk, straight edge

Primer (Jointing compound)

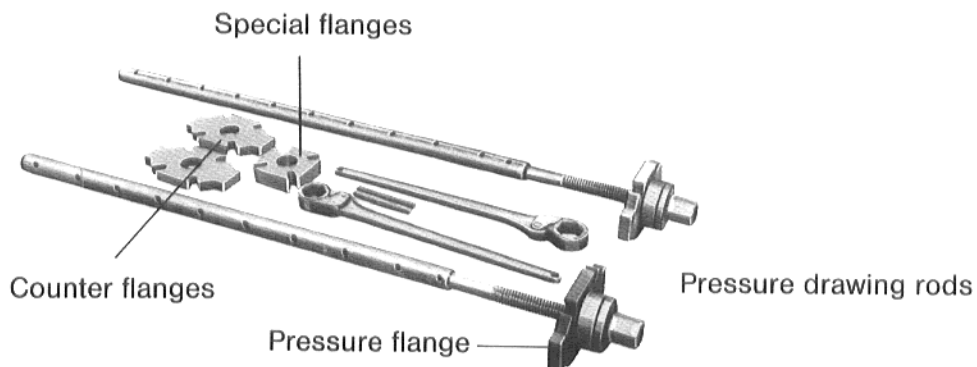

Picture 1

① **Boiler foundation**

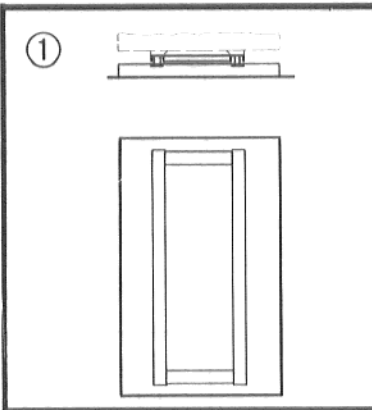

② **Technical data and boiler dimensions**

②

Technical Data

Model	Power (kW)	Power (hp)	Water capacity (l)	Weight (kg)
1000	10	13.6	10	10
1500	15	20.4	15	15
2000	20	27.2	20	20
2500	25	34.0	25	25
3000	30	40.8	30	30
3500	35	47.6	35	35
4000	40	54.4	40	40
4500	45	61.2	45	45
5000	50	68.0	50	50
5500	55	74.8	55	55
6000	60	81.6	60	60
6500	65	88.4	65	65
7000	70	95.2	70	70
7500	75	102.0	75	75
8000	80	108.8	80	80
8500	85	115.6	85	85
9000	90	122.4	90	90
9500	95	129.2	95	95
10000	100	136.0	100	100

③ **Assembly of boiler sections**

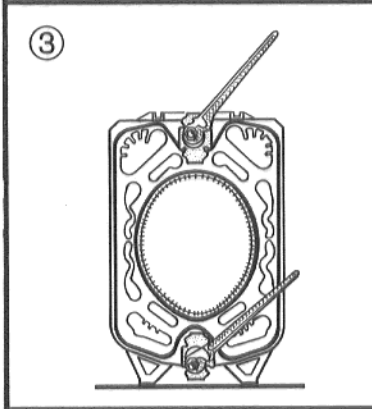

④ **Hydraulic test**

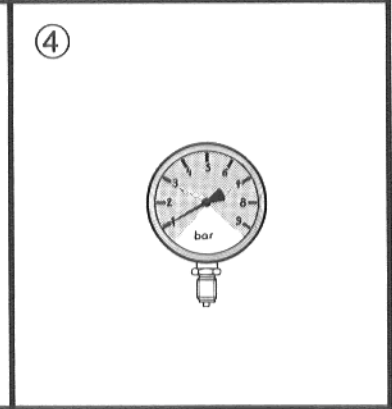

⑤ **Installation and tightening of fittings (Front section)**

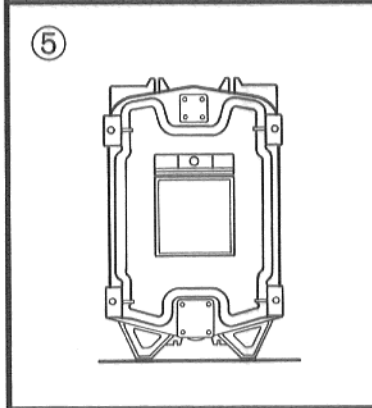

⑥ **Installation and tightening of fittings (Rear and connection section)**

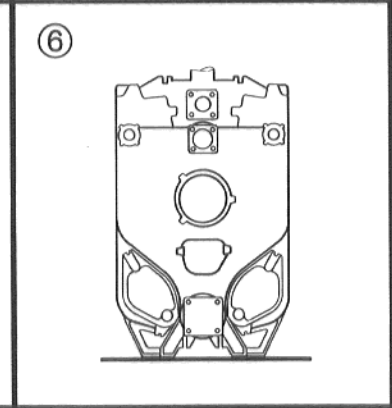

⑦ **Assembly of burner**

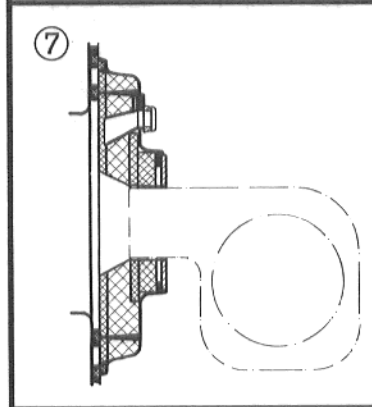

⑧ **Assembly of boiler casing**

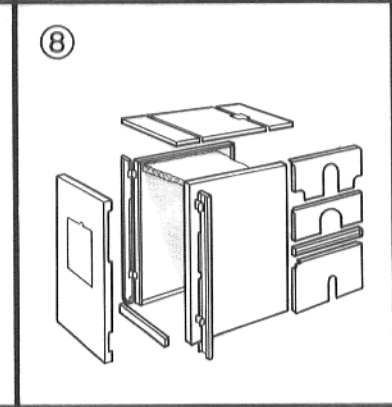

⑨ **Cleaning and maintenance**

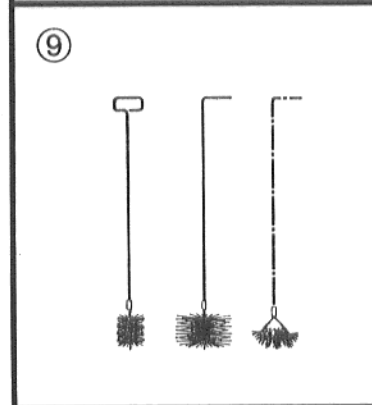

⑩ **Control of the return temperature**

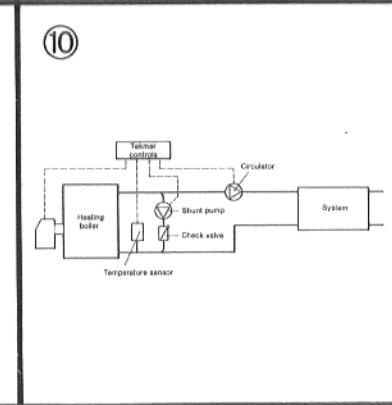

Boiler foundation

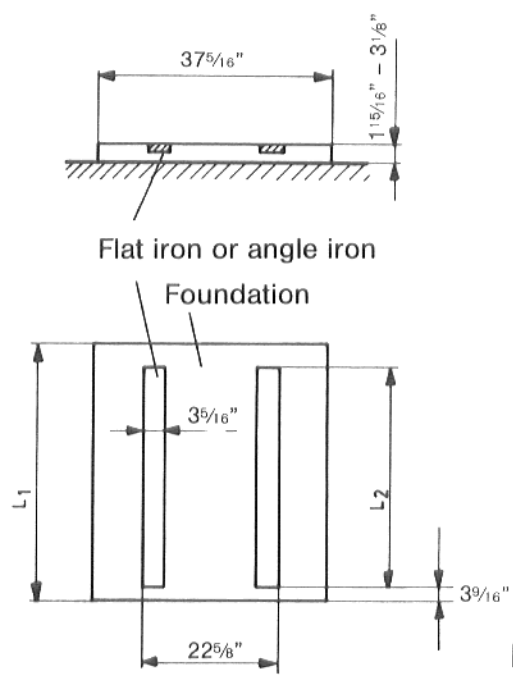

Picture 2

Boiler lay-out

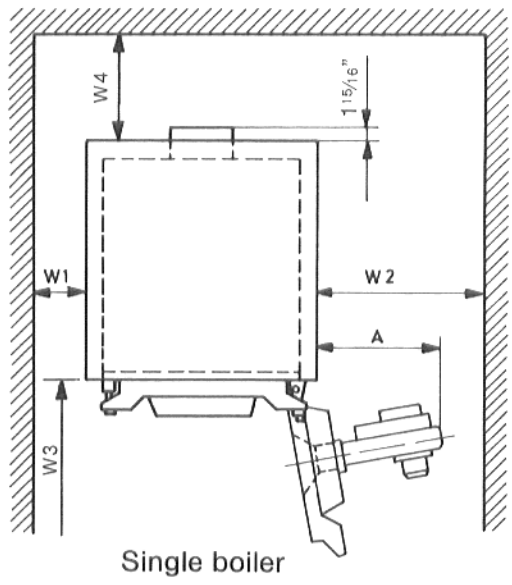

Single boiler

Picture 3

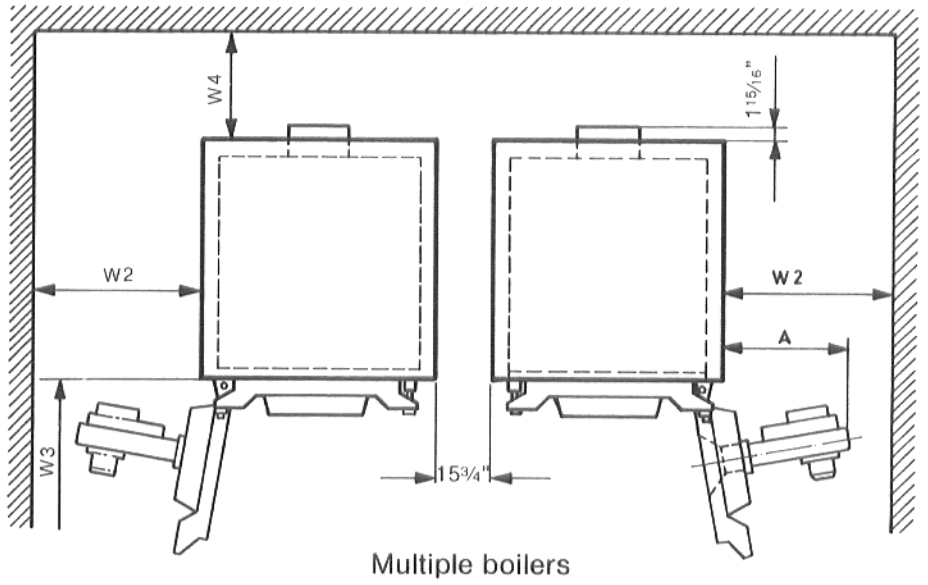

Multiple boilers

Picture 4

1. Boiler foundation

We recommend that the boiler is mounted on a concrete base, which is 2 – 3 inches high, even and horizontal.

When pouring the base it is useful to cast in either 4" x 3/16 inch flat iron or 4" x 2" x 1/4 inch angle iron (Picture 2).

The foundation loading, if flat or angle iron is used, amounts to 14.2 psi.

Foundation dimensions and length of flat or angle iron

No. of boiler sections	8	9	10	11	12	13	14	15
Foundation dimension "L ₁ " (inch)	50	55 1/2	61	66 1/2	72 1/16	77 9/16	83 1/8	88 5/8
Flat iron or angle iron "L ₂ " (inch)	43 11/16	49 1/4	54 3/4	60 1/4	65 3/4	71 1/4	76 3/4	82 5/16

If a sound absorbing foundation frame is used, see chapter below.

Mounting the boiler

Please note minimum dimensions between boiler and wall to allow for opening of burner door and also for installation and removal of boiler casing.

If multiple boilers are used, particular care must be taken.

The burner door may be mounted left hand or right hand, depending on which way it has to open.

Distance to wall of burner: "W₂" = burner projection: "A" + 4 inches; (minimum 32 inches).

Distance to wall: "W₁" minimum 20 inches.

To satisfy boiler room guide lines the following dimensions must be maintained:

In front of the boiler: Boiler length "L" + 39 inches = W3

Behind the boiler: 1/2 of boiler length + 20 inches = W4

(see Pictures 3 and 4).

Assembly of boiler sections, with tie rods inserted, burner door fitted but without boiler casing

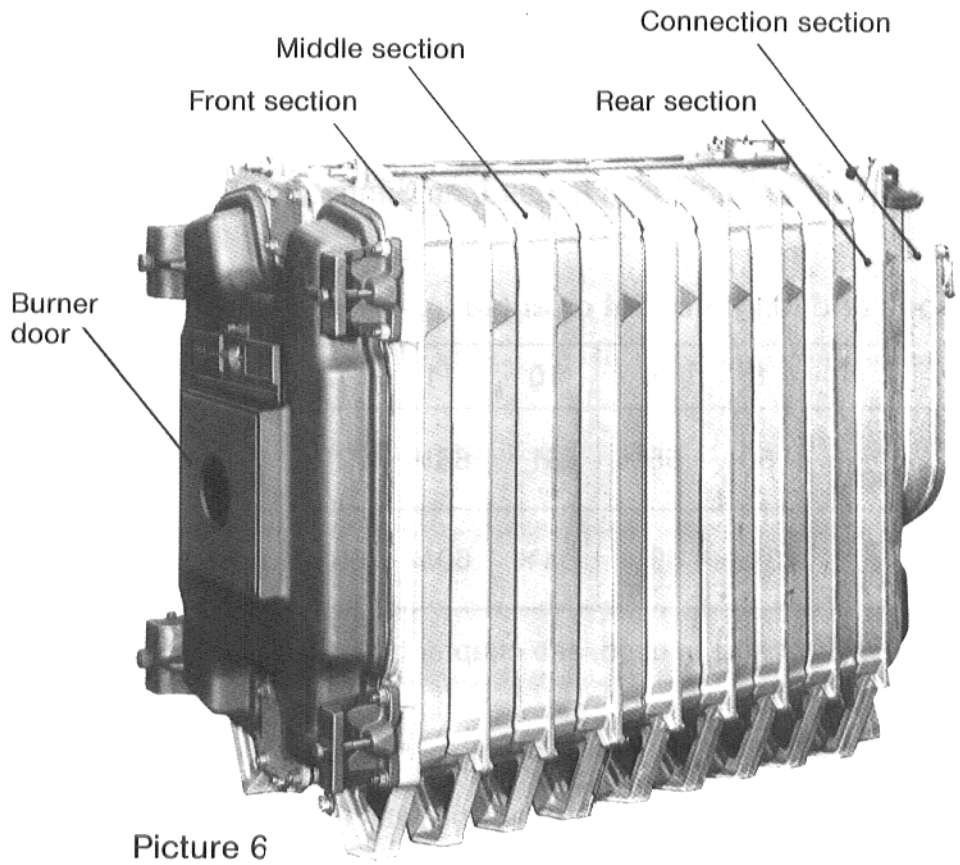

Picture 6

Boiler with boiler casing

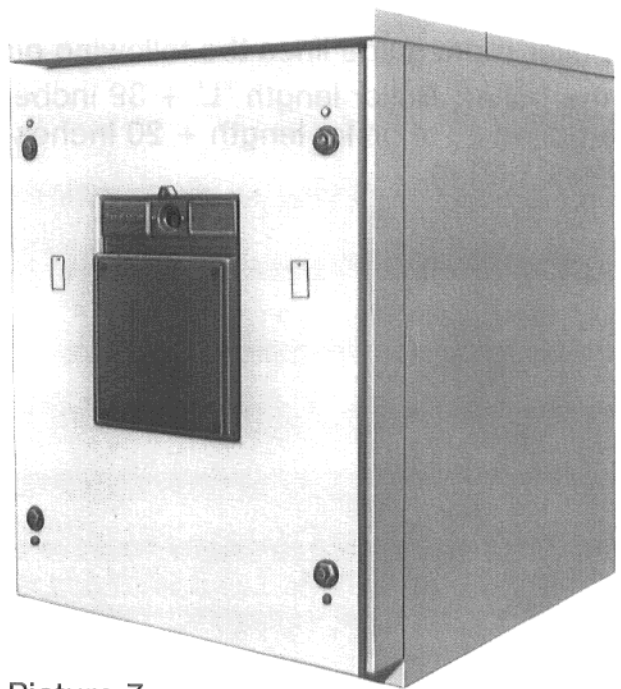

Picture 7

2. Technical data and boiler dimensions

Number of sections		8	9	10	11	12	13	14	15
Technical data									
Gross output I-B-R	[MBtu/h]	972	1062	1151	1241	1330	1420	1509	1599
Boiler HP		29.0	31.7	34.4	37.1	39.7	42.4	45.1	47.8
Net I-B-R rating	[MBtu/h]	845	923	1001	1079	1157	1235	1312	1390
Maximum input oil	[gph]	8.10	8.80	9.60	10.40	11.00	11.80	12.60	13.20
Maximum input gas	[MBtu/h]	1167	1273	1380	1487	1593	1700	1806	1913
Overall efficiency oil	[%]	85.9	86.0	86.0	86.0	86.1	86.1	86.1	86.2
CO ₂ content oil	[%]	13							
Stack gas flow oil	[lb/hr]	1006	1101	1193	1288	1383	1475	1570	1662
Overall efficiency gas	[%]	83.3	83.4	83.4	83.5	83.5	83.5	83.5	83.6
CO ₂ content gas	[%]	9.9							
Stack gas flow gas	[lb/hr]	1046	1142	1241	1337	1433	1532	1627	1727
Positive pressure in firebox	[in · H ₂ O]	0.46	0.49	0.52	0.55	0.58	0.60	0.63	0.66
Flue gas temperature (gross)	[°F]	374	374	374	373	373	373	373	373
Dry weight	[lbs.]	3321	3650	3974	4293	4633	4952	5272	5592
Boiler water content approx.	[gal.]	66	74	82	90	98	106	114	122
Boiler dimensions									
Total casing length L _K	[in.]	50	55½	61	66½	72	77½	83	88½
Depth of combustion chamber T	[in.]	37¾	42¾	48¾	53¾	59¾	64¾	70¾	75¾
Operating data									
Max. boiler temperature	[°F]	240							
Max. operating gauge pressure	[psi]	58							

Front view

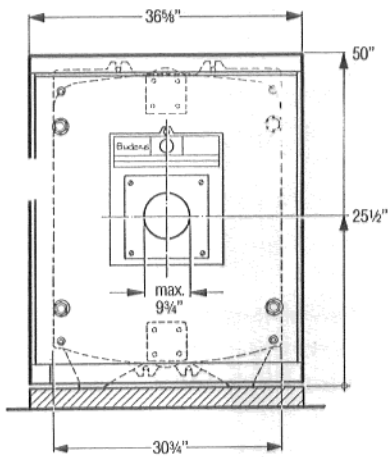

Side view

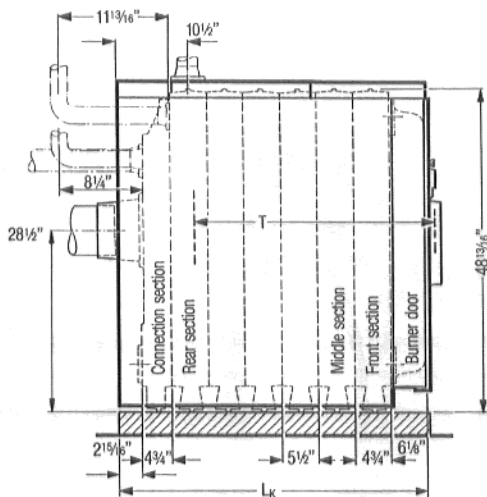

Rear view

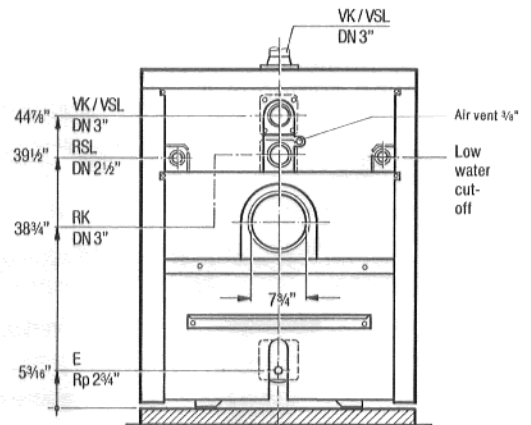

DN = Diameter
E = Vent / Drain
L_K = Boiler casing length

VK = Boiler supply
RK = Boiler return
Rp = Female thread

RSL = Expansion
VSL = Safety relief
T = Depth of combustion chamber

Arrangement of boiler sections

Front section, middle section(s), rear section and connection section.

When assembling sections please note direction arrows (Picture 8) and proceed as shown in the table below.

The connection section is always installed last.

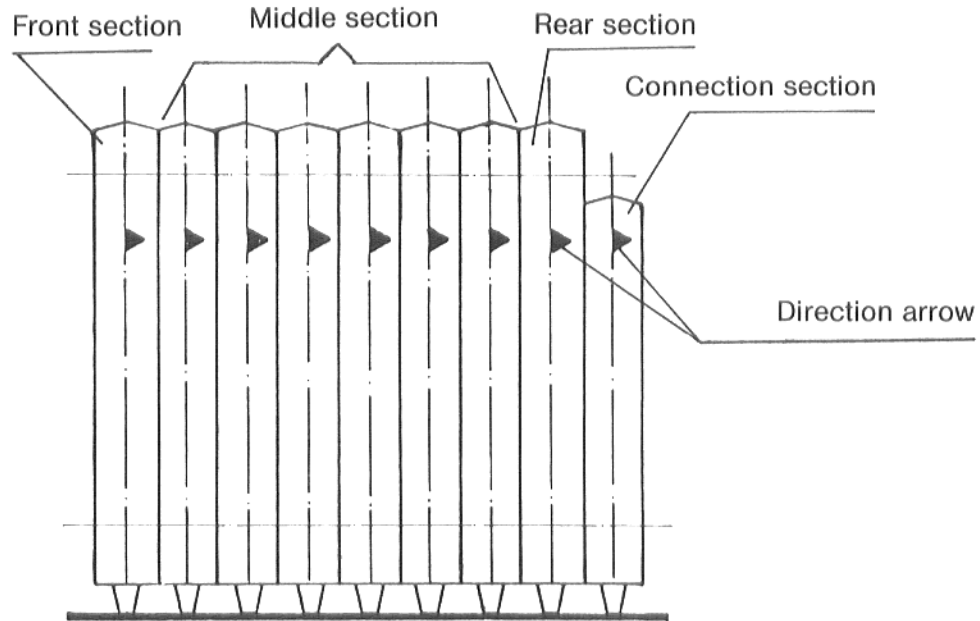

Picture 8

No. of sections	Front section	Middle section	Rear section	Connection section
8	1	5	1	1
9	1	6	1	1
10	1	7	1	1
11	1	8	1	1
12	1	9	1	1
13	1	10	1	1
14	1	11	1	1
15	1	12	1	1

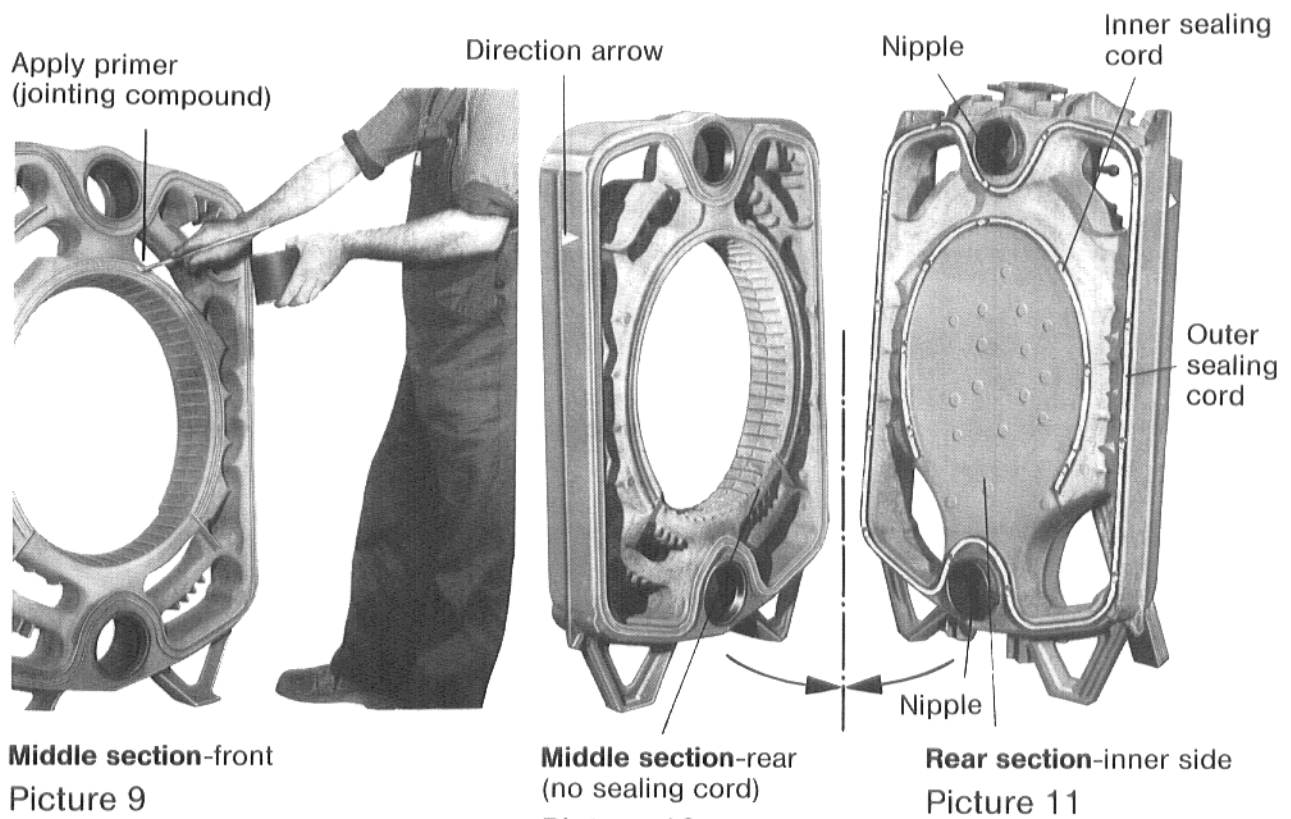

3. Assembly of boiler sections

General

Attention: Simple sealing of sections!

Before assembling the front, rear and connection sections, remove studs, nuts and washers. When assembling the sections watch for the white **direction arrows** the on right and left hand side. The arrow points to the rear of the section. The method of assembly is a tongue and groove system. All parts must be **dry** and **clean**.

The sections are made tight using Buderus sealing cord, which is supplied. The sealing cord is **only inserted on the front side of the section** (as seen from the direction of assembly). It is supplied, stuck to paper in rolls. Remove sealing cord from paper, insert into the groove of the section and press home lightly. The sealing cord can be cut with scissors or a knife. Push joints together tightly.

All butt joints (beginning and end of stranded cord) should overlap.

Any boiler mountings which have to be removed or opened during servicing are made tight with a stranded sealing cord.

All grooves which are jointed with Buderus sealing cord must be prepared by the application of jointing compound, with a brush, over their length and width (Picture 9). During the drying period of 5 – 45 minutes the sealing cord may be inserted and the sections can be mounted.

Attention! Please read the following carefully **when using Primer 181** for sealing compounds.

The Buderus Primer 181 for sealing compounds serves as bonding agent on porous grounds, metal and similar. The Primer is applied by means of brush.

Observe a drying and ventilating period of 5 – 10 minutes.

When using, formation of explosive / easily inflammable vapor / air mixtures is possible, therefore use only in well ventilated areas.

Keep away from sources of inflammation. Do not smoke. Avoid Primer from getting into the drain channels.

Assembly

Place **rear section** in position, ensure it does not tilt over.

When positioning the rear section, on the base or on the sound absorbing base, ensure that the depth of the connection section ($3\frac{5}{16}$ inches) is provided for, as this section will be fitted last (after the front and all middle sections).

Preparation of nipples and bosses

First clean both nipples and bosses with a solvent soaked rag and then coat evenly with red lead oxide. Before using the oxide any free oil should be drained off.

To insert **nipple**.

(Nipple size: $4\frac{1}{16}$ / $2\frac{3}{8}$ inches). $4\frac{1}{16}$ inches = inside dia; $2\frac{3}{8}$ inches = width.

The nipple should be inserted squarely in the upper and lower boss on the rear section and driven home with light blows from a wooden or rubber mallet, striking crosswise direction. If the nipple is scored during this operation it must be removed immediately.

Apply primer jointing compound to sealing groove, supplied by Buderus.

Insert **elastic sealing cord** into the **inner** and **outer groove** on the inner side of the rear section and press home lightly (Picture 11).

Select **first middle section**.

Clean bosses and coat with red oxide.

Apply first **middle section** to rear section.

Clean nipple and coat with red oxide.

Insert nipple into upper and lower boss and drive home with light crosswise hammer blows.

Coat outer and inner groove on front side of the section with sealing compound.

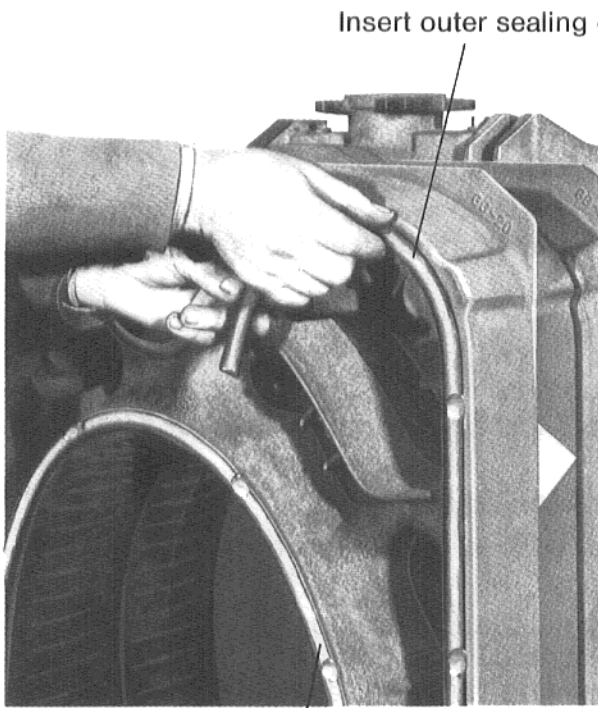

Picture 12 Insert inner sealing cord

Pictures 12 and 13 show the front side of the middle section.

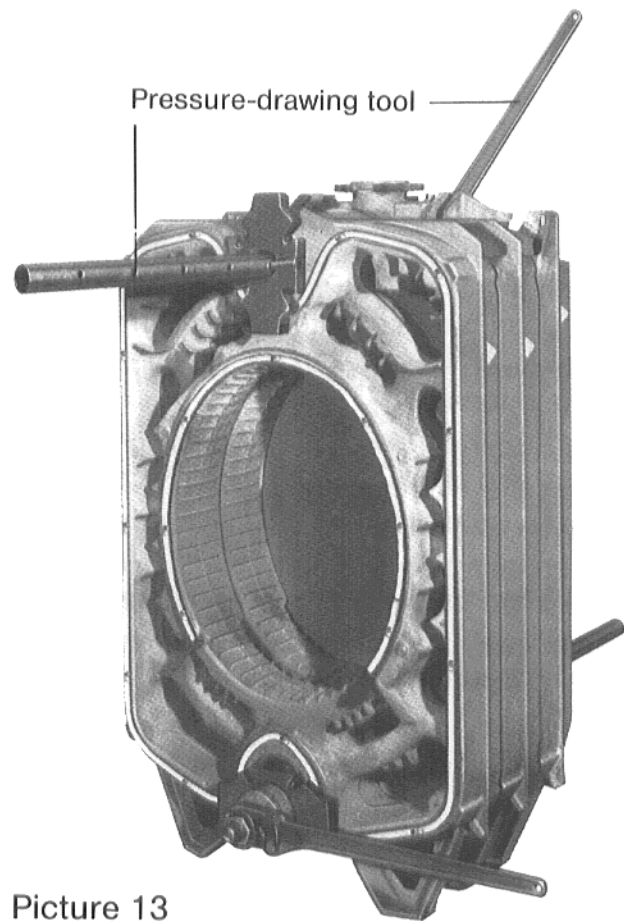

Picture 13

Using pressure-drawing tools: Here for example 7 section boiler block (top view)

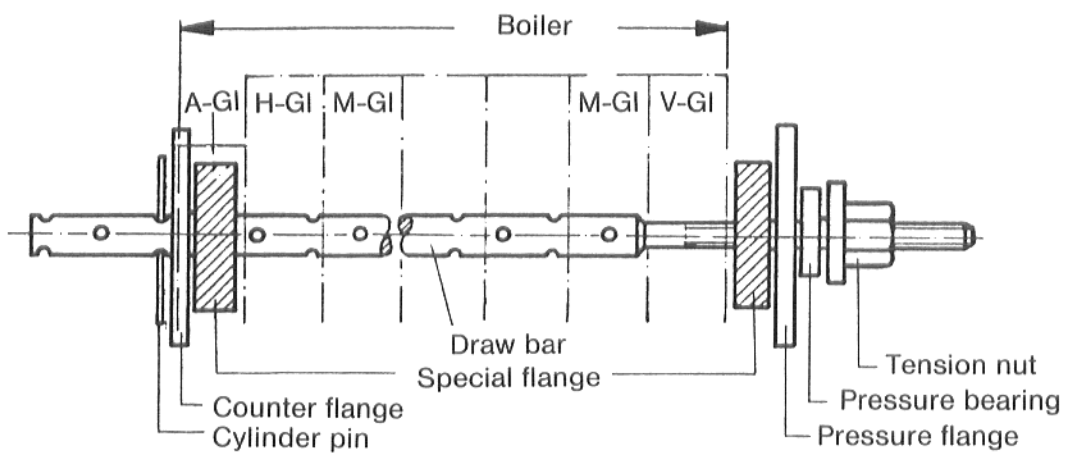

- A-GI = Connection section
- H-GI = Rear section
- M-GI = Middle section
- V-GI = Front section

Picture 13 a

Insert Buderus sealing cord into inner and outer groove on the front side of the section and press home lightly (Picture 12).

Select **second middle section**.

Clean bosses and nipples and coat with red oxide.

Apply **second section** to first section. Insert nipple.

Coat outer groove on front side of the section with sealing compound.

Insert Buderus sealing cord into inner and outer groove on the front side of the section and press home lightly (Picture 12).

Use **drawing rods**, by inserting through upper and lower bosses, to press home sections evenly (Picture 13 *).

Assembly should proceed in stages so that no more than 2 sections at any time are pressed home.

Now continue assembly of all middle sections as described above.

The **front section** is the last but one to be mounted as follows: Use only **stranded sealing cord** and insert into inner and outer groove on the front side of front section!

Attention!

If the boiler sections meet so that the surfaces of 2 bosses touch one another, then no further pressure must be applied.

When using the pressure assembly tools, 1 special flange each has to be used on the outside of the front section high and low level and on the rear section high level and on the connection section low level.

*) Using pressure-drawing tools during assembly or service. 2 pressure-drawing tools are required per boiler (see also picture 13 a).

1 set of pressure-drawing tools consists of:

1 draw bar, 1 tensioning nut, 1 pressure bearing, 1 pressure flange, 1 counter flange, 1 cylinder pin, 2 special flanges**), 1 ratchet ring spanner.

) Special flanges. Use only on front section **high/low level, as well as on rear section **high level** and connection section **low level**.

Do not use for assembly of middle sections.

The fourth special flange is only required in case of repair work.

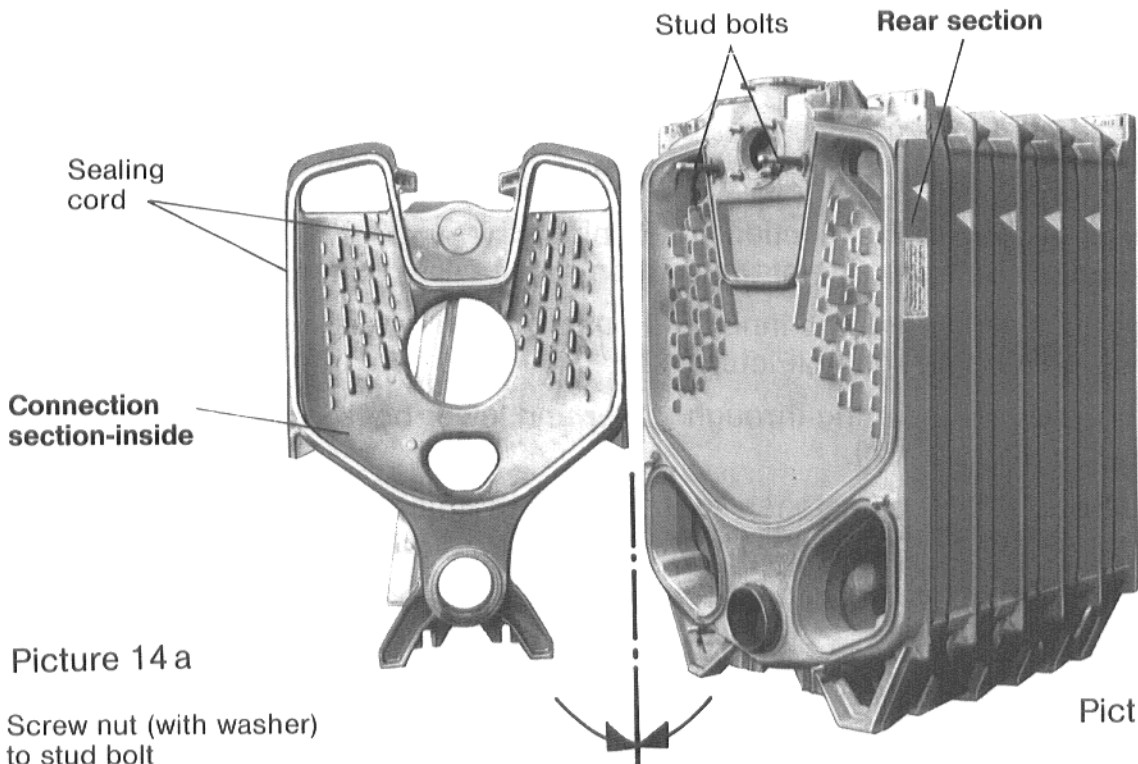

Picture 14 a

Picture 14

Screw nut (with washer) to stud bolt

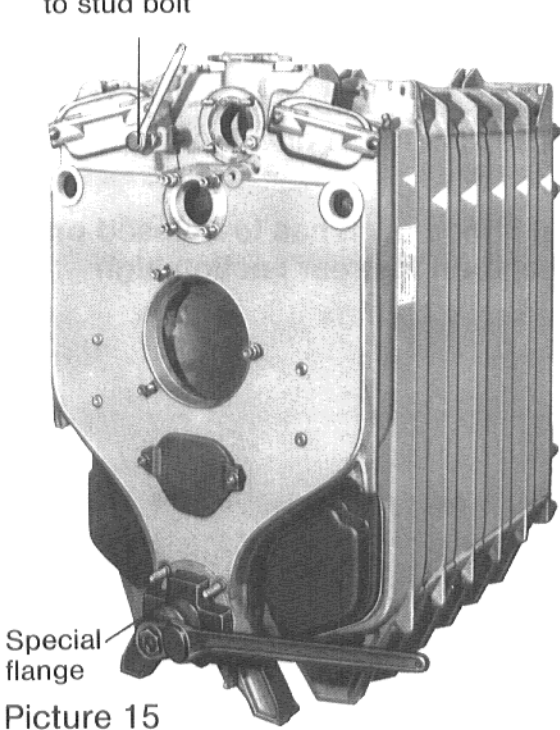

Picture 15

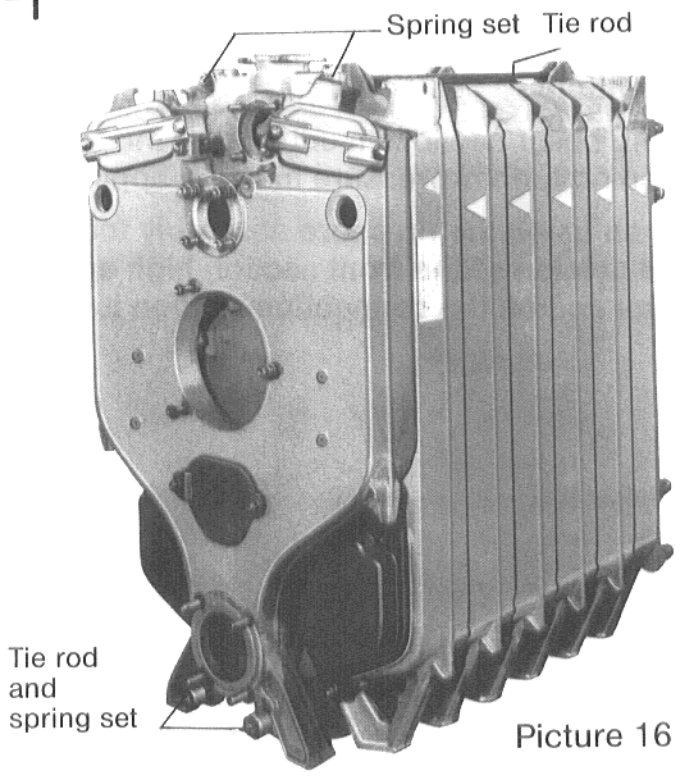

Picture 16

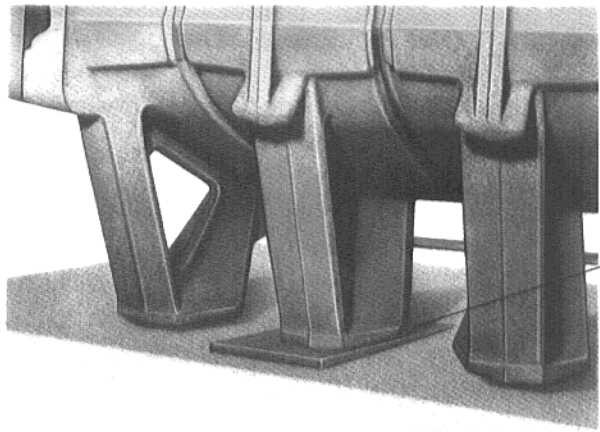

Picture 17

Select connection section.

Clean bosses and nipples.

Insert lower nipple in rear section and drive home.

Screw studs into rear section (Picture 14).

Apply sealing compound to groove on the **inside of the connection section** and insert sealing cord (Picture 14 a).

Fit connection section to rear section.

The connection section is secured to the rear section at low level via the nipple connection of the lower boss by means of the pressure-drawing tools.

For this purpose use 1 special flange each at low level on front section and connection section.

At high level the connection section is secured by 2 nuts M16 on the stud screws of the rear section (see also Picture 15).

Take care that pressing through the lower boss (nipple connection) and slipping-on over the two upper stud bolts is effected simultaneously and evenly.

After pressing together the boiler, just loosen both pressure-drawing tools; **do not remove them yet.**

Fitting up tie rods

The short tie rods (2) are inserted left and right side, **high level**, near the boss (Picture 16).

They stretch from the front to the rear section.

The long tie rods (2) are inserted left and right side **low level**.

Depending on space available, they may be pushed under the boiler from the front or the rear and placed into the recess below the boss. They stretch from the front section to the connection section.

On the **front side** of the **boiler** the **thick washers** provided are now slipped over the tie rods and the nuts screwed home.

On the **rear side** of the **boiler** the **spring sets** are slipped over the tie rods and nuts are made hand tight (Picture 16). (Spring sets should be used as a complete unit and not undone!)

Now the nuts on the boiler rear side may be tightened 1 to 1½ turns using a ring spanner.

The boiler should now be vertically and horizontally lined up.

After the boiler has been aligned all section feet should be checked and cardboard or paper inserted between feet and foundation. Where feet are well short of the base sheet metal strips or flat wedges should be used (Picture 17).

Now remove pressure drawing tools!

The **sensor pocket** (6" long) can now be made into the rear section (Picture 19, page 16).

Sheet metal strips or flat wedges may only be used under short feet if no sound absorbing foundation frame is employed.

**Front elevation
without
burner door**

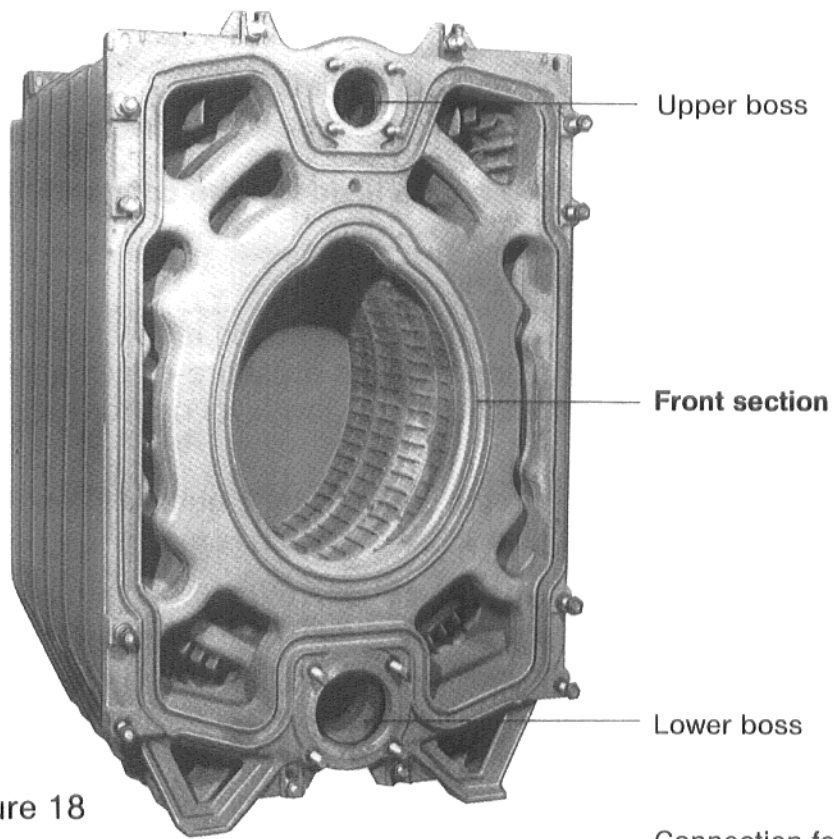

Picture 18

Rear view

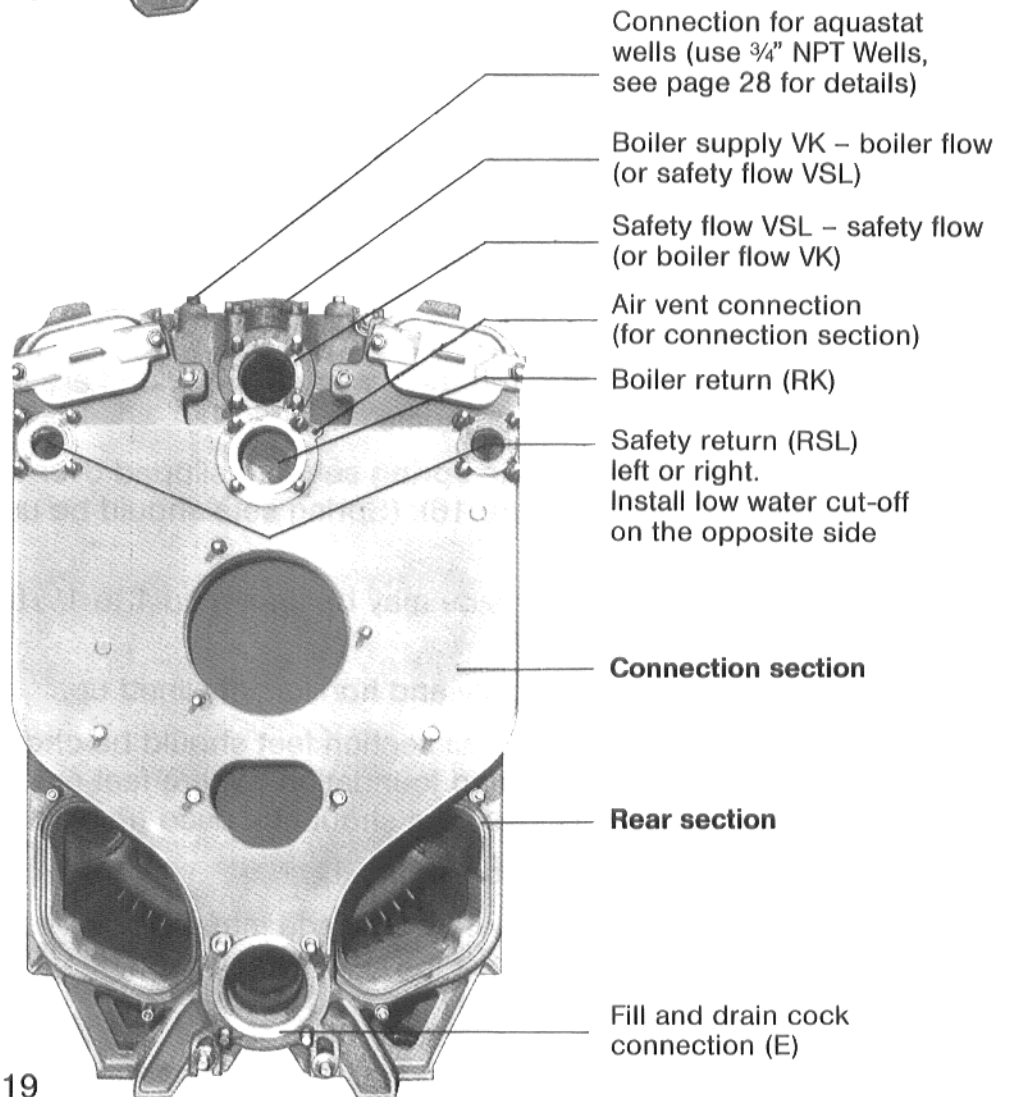

Picture 19

4. Hydraulic test

The nuts and washers previously removed from the studs in the bosses, centre high level and low level, are now required.

Preparation for the leakage test

While the hydraulic leakage test is carried out all pressure control and safety instruments, which cannot be isolated, must be removed to avoid damage due to high pressure.

- a) Blank the upper and lower boss on the **front section** using a gasket and blank flange.
- b) Blank the safety return, high level and right (RSL) and the boiler return connections, high level center (RK) on the **connection section** as well as the filling and drain cock connection (E), low level center on the same section.
- c) On the **rear section** the safety supply, high level center (VSL), and the boiler supply connection, center facing upward (VK), must be blanked.
Also on the rear section, high level, the connections for measuring and control instruments have to be blanked, using sensor pockets or plugs.
- d) **Attention! Filling of the boiler:**
Fill only from the bottom using the filling and drain cock.
- e) **Air venting of the boiler:**
During the filling operation venting should be carried out periodically, on the rear and connection sections until water flows from the vent connection.

If one of the boss connections leaks during the test, then water must first be drained via the drain cock and the tie rods should then be removed.

The boiler must then be split at the leakage point, using flat wedges (chisels) in a side wise direction, on the upper and lower bosses of the sections.

When re-assembling the boiler it is imperative to use **new nipples**.

Re-assemble boiler and repeat leakage test.

Leakage test

The leakage test must be carried out in accordance with local regulations and HC 410.

HC-410.2 Hot Water Boilers

All hot water heating or hot water supply boilers marked for working pressures not over 30 psi shall have each individual section or boiler part subjected to a hydrostatic test of not less than 60 psi at the shop where made. Hot water heating and hot water supply boilers marked for working pressures over 30 psi shall have each individual section or boiler part subjected to a hydrostatic test of 2½ times the maximum allowable working pressure at the shop where made. The assembled boiler shall be subjected to a hydrostatic test pressure not less than 1½ times the maximum allowable working pressure.

HC-410.3 Required Test Pressure

In making hydrostatic pressure tests, the pressure shall be under such control that in no case shall the required test pressure be exceeded by more than 10 psi.



Burner door

Picture 20

Stranded sealing cord

Door closing bracket

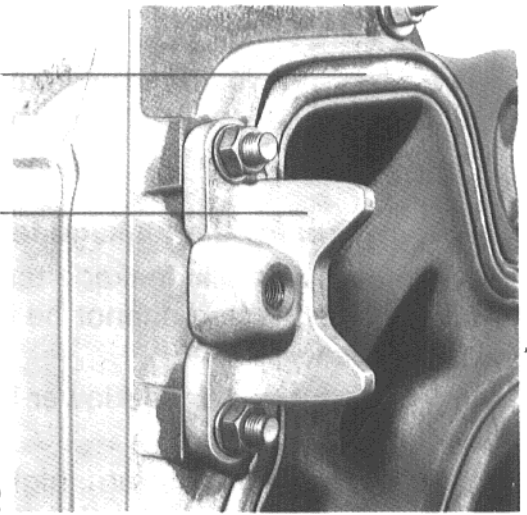

Picture 22

Hinge bracket with hinge fastening

M 15/16"

Tie rod

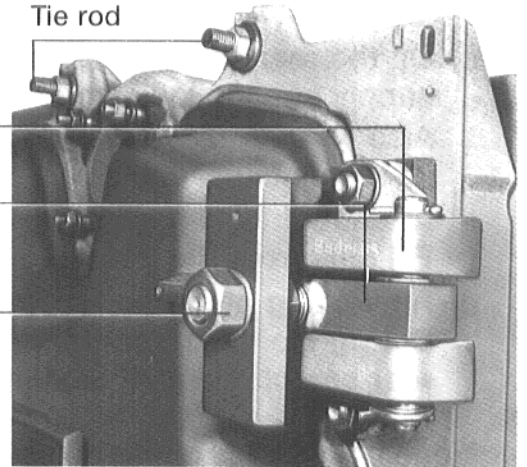

Picture 23

Stranded sealing cord

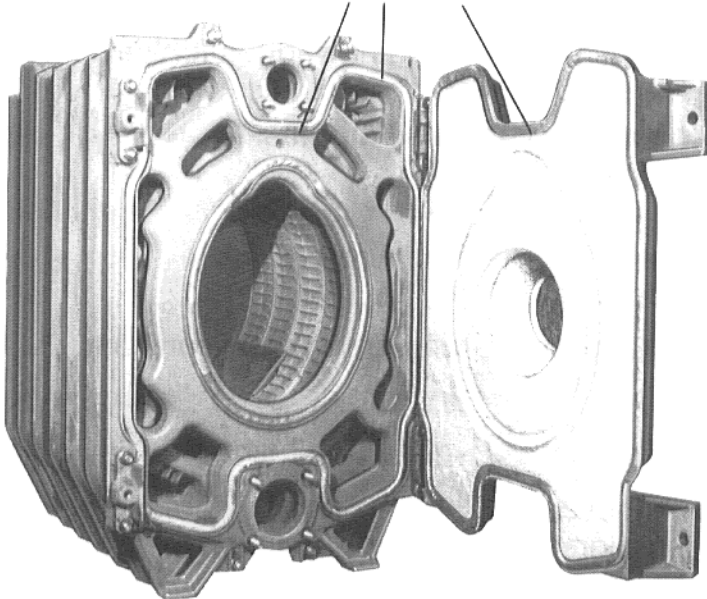

Picture 21

Boiler block with open burner door
- hinged right hand -

Flat nut
M 15/16"

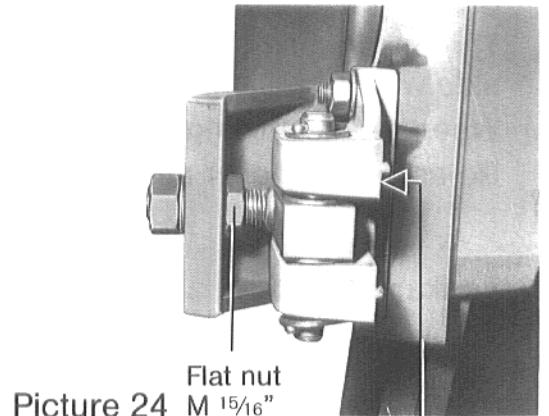

Picture 24

Contact surface for boiler casing

Abutting surface

Hexagon bolt
M 5/8" x 3 15/16"

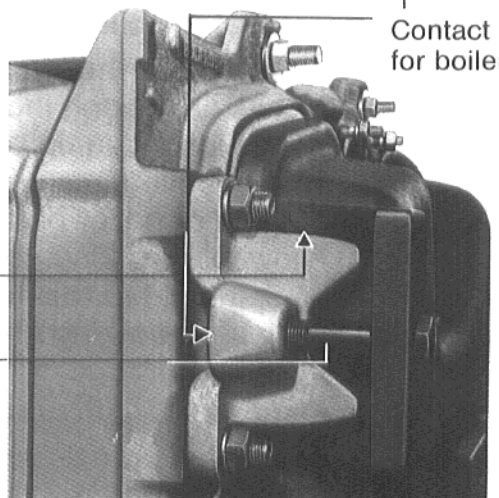

Picture 25

5. Installation and tightening of fittings (Front section)

Slide hinge bracket, catch and bolts over the appropriate studs, both high and low level on front section, depending on left or right hand opening and fasten using nuts and washers (Picture 23).

Slide door closing bracket, at high and low level on front section, over the studs on the opposite side of required door opening, and fasten with nuts and washers (Picture 22).

Burner door

Remove front nut (M $1\frac{5}{16}$ "") and washer from the door hinge catch (Picture 23).

The burner door should be lifted up (approximately 8"), using timber packing and made steady, before mounting it.

Another method of assembling is:

Place burner door in position, lift left or right hand side and insert bolts through burner door lower fastening hole into the hinge fastening plate and screw on nut to make it safe.

Now lift door and fasten the corresponding upper hinge (Picture 20).

Stranded sealing cord has been inserted by the factory into the outer groove of the door. At the same time insert stranded sealing cord into the inner and outer groove of the front section ($\frac{3}{4}$ inch dia.) (Picture 21).

Opening and closing of the door

For nuts and bolts always use correct spanners!

Closing

Drive flat nuts M $1\frac{5}{16}$ " on the inside of the hinges (upper and lower) back to the stop.

The burner door should now be lifted and pressed home at the same time so that it sits on its support surface, and the left, upper hexagon M $\frac{5}{8}$ " x $3\frac{15}{16}$ " made hand tight.

If door is hinged on left hand side then reverse the procedure.

Both hexagon screws M $\frac{5}{8}$ " x $3\frac{15}{16}$ " and both nuts M $1\frac{5}{16}$ " may now be tightened, proceeding crosswise.

The afore mentioned flat nut M $1\frac{5}{16}$ " must now be tightened again against the hinge.

Opening

Remove both hexagon screws M $\frac{5}{8}$ " x $3\frac{15}{16}$ ", left if hinged on right and right if hinged on left hand side (Picture 25).

Open door.

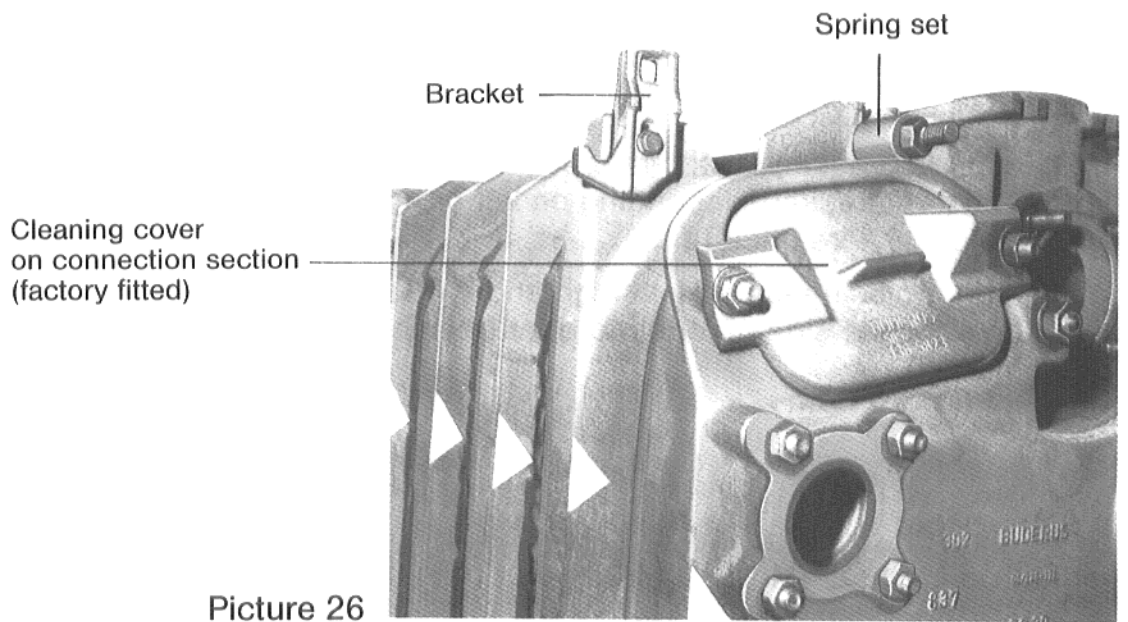

Picture 26

Rear view

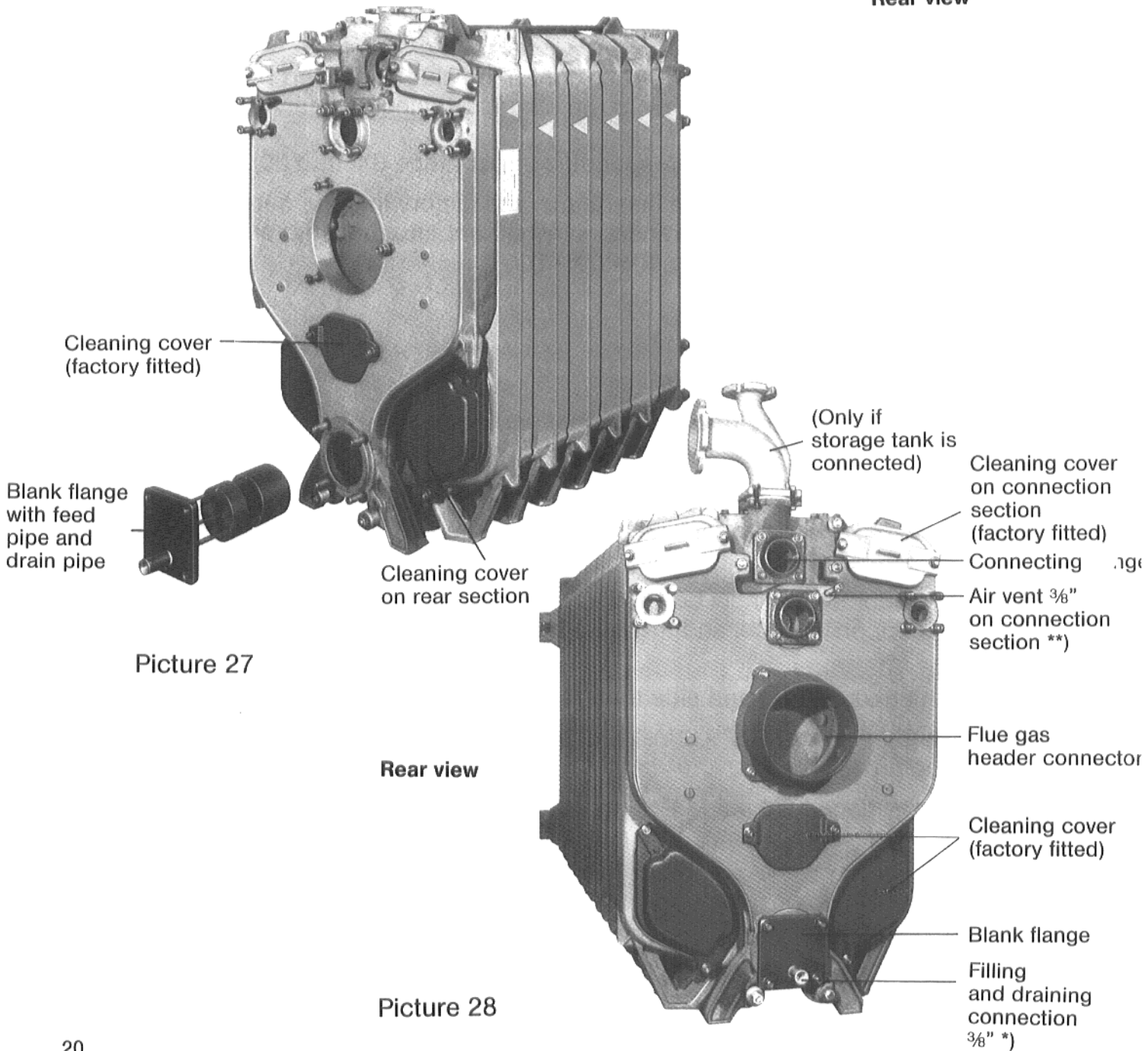

Picture 27

Rear view

Picture 28

6. Installation and tightening of fittings (Rear and connection section)

Upper cleaning covers (high level left and right) on the connection section (Picture 26).

Both covers are factory fitted.

Lower cleaning cover (middle) on the connection section (Picture 27).
The cover is factory fitted.

Flue header (on connection section) (Picture 28).

Push over the 3 studs on the connection section and tighten nuts.
The stranded sealing cord is already inserted.

Cleaning cover (on the rear section low level right and left) (Picture 27).
The cleaning covers are factory fitted.

Blank flange with feed pipe and drain connection ($\frac{3}{4}$ "). Fit on connection section on the lower boss (Picture 27). *)

Note: Do not forget gaskets when fitting blank or connecting flanges on the boiler rear or front ends as well as the upwards facing discharge.

*) Drain pipe socket $\frac{3}{4}$ " factory fitted to flange.

***) The air vent valve $\frac{3}{8}$ " (4 inches long) together with vent valve $\frac{3}{8}$ " has to be site fitted (Picture 28).

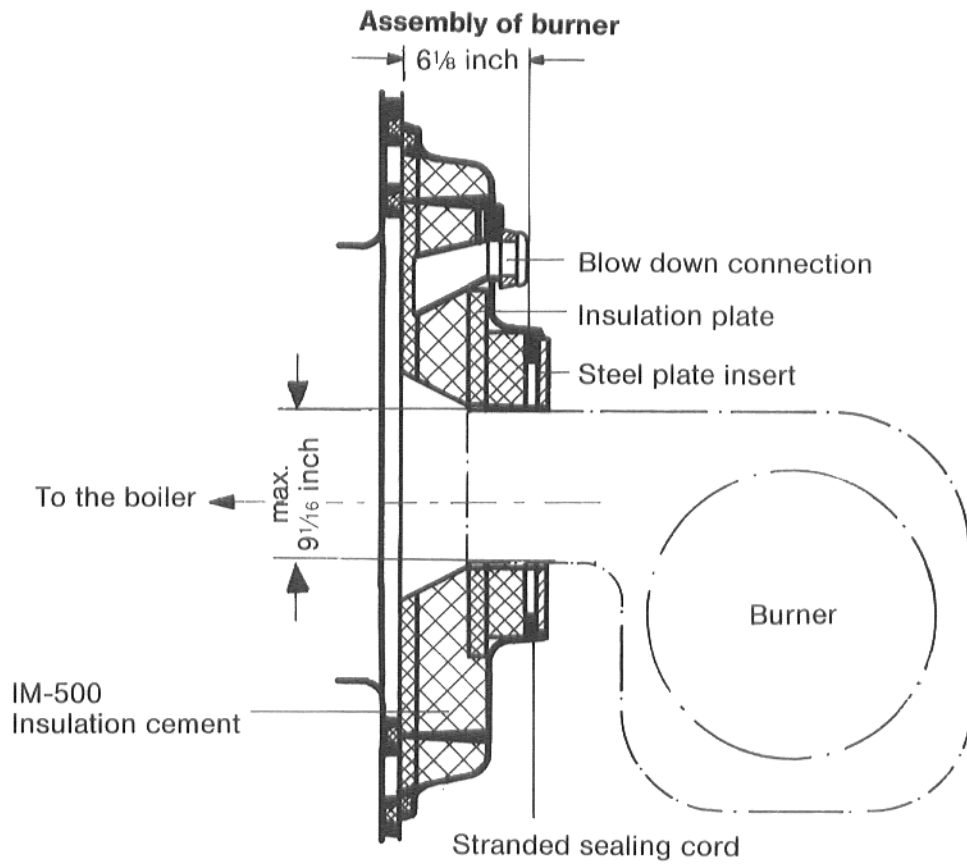

Picture 29

Flue gas header connector / Flue pipe

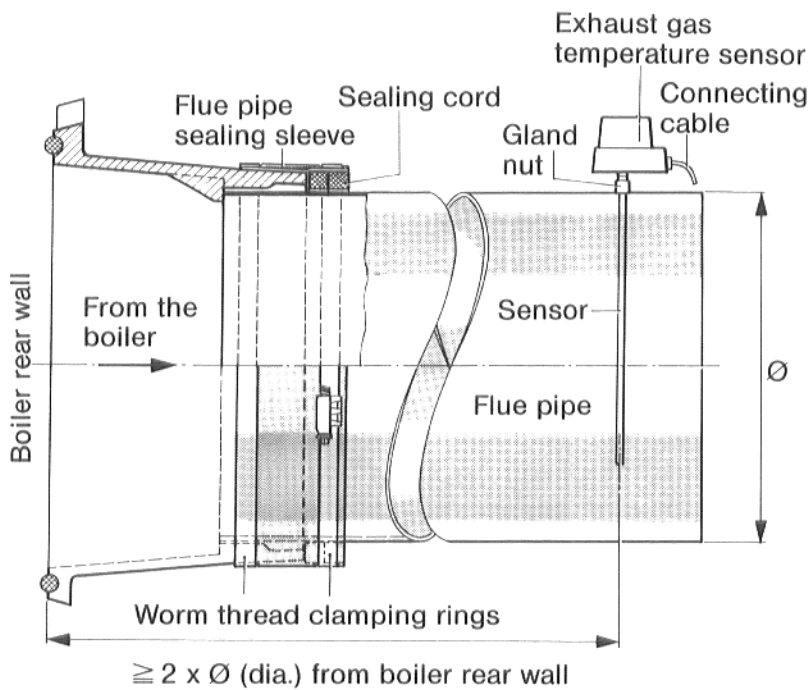

Picture 30

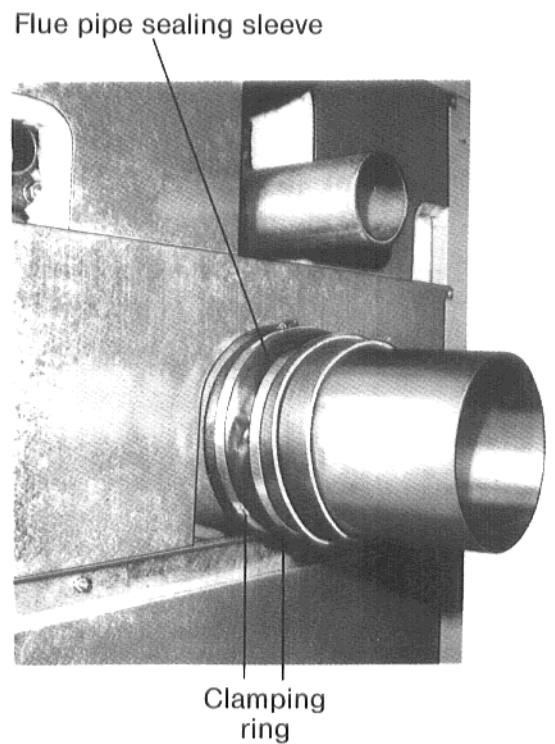

Picture 31

7. Assembly of burner

Before the burner is mounted the burner door casing must be mounted!

The remainder of the boiler casing can be mounted later i. e. before operation commences.

If the factory has been notified of the burner tube diameter then the steel plate insert will have been bored out to fit. If this information was not available then the steel plate must be bored on site (Oxyacetylene cut).

Maximum burner tube diameter of the burner plate: 10".

Drill burner mounting holes and cut threads.

Screw **steel plate insert** to burner door then make tight using stranded sealing cord.

Cut **insulation plate** to suit burner tube.

Wrap corrugated paper, or similar, around the **burner tube** making sure that it cannot roll up.

Mount **burner**.

Any spaces left between the burner tube and the factory pressed out burner door cover (this will depend on the burner tube diameter) must be filled with insulating cement (IM 500).

(IM 500 in sufficient quantity is supplied. Please note instructions for its preparation.)

The **blow down connection** for the sight glass fitting should be connected to the burner to avoid the formation of deposits.

Flue pipe

The joint between flue pipe and connector must be made tight by stuffing with sealing cord or similar. This connection must be **gas tight**.

Exploded view of the boiler casing

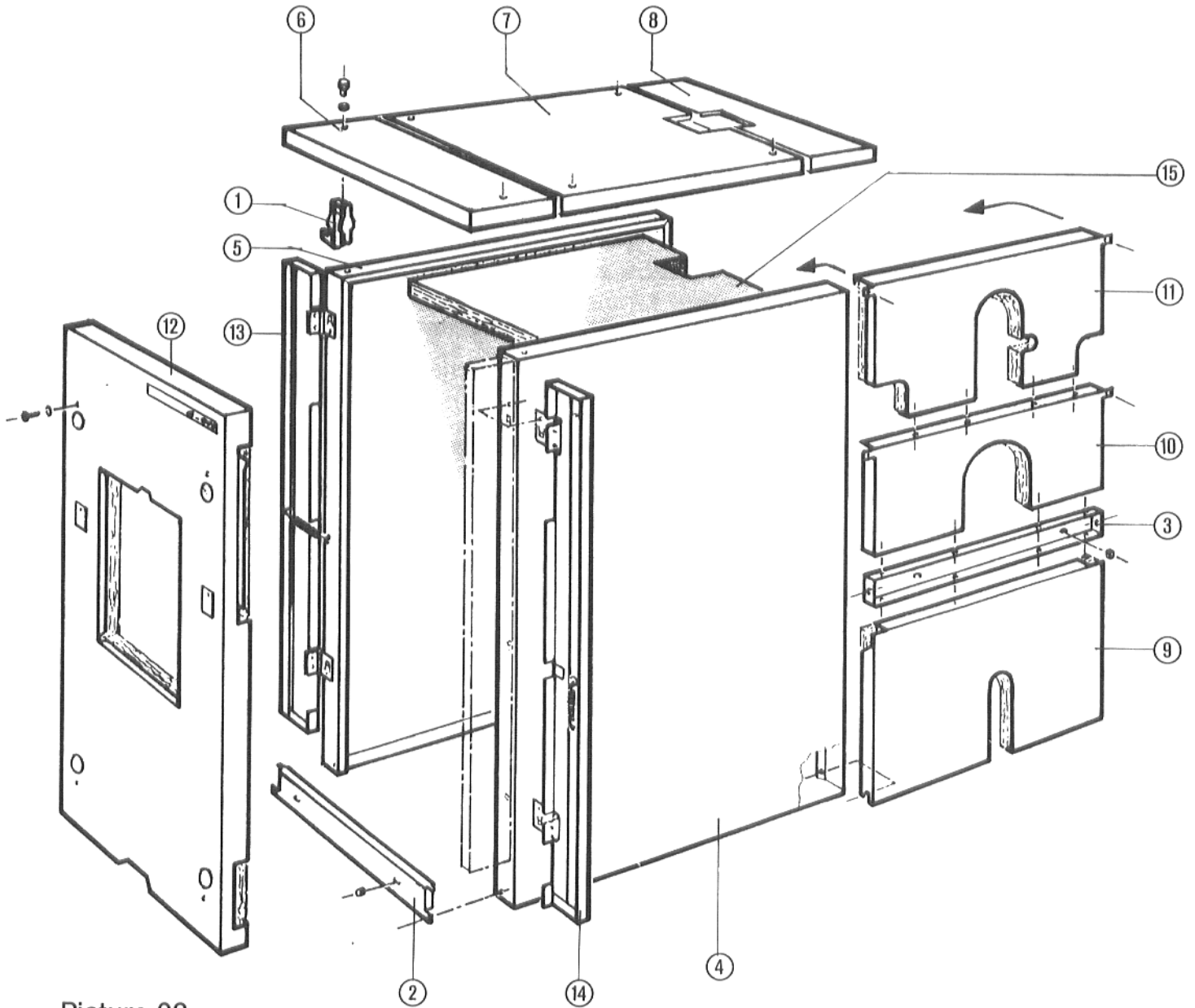

Picture 32

8. Assembly of the boiler casing

Overall view and shortened assembly instructions (Pictures 32 – 38).

Attention!

Before mounting the burner the burner door cover must be installed ⑫.

Individual parts:

- | | |
|-------------------------------------|------------------------------------|
| ① Brackets (4 / cast iron) | ⑨ Rear, lower part of boiler wall |
| ② Front transom plate | ⑩ Rear, middle part of boiler wall |
| ③ Rear transom plate | ⑪ Rear, upper part of boiler wall |
| ④ Right hand side wall | ⑫ Burner door cover |
| ⑤ Left hand side wall | ⑬ Left hinge bracket |
| ⑥ Front part of boiler hood | ⑭ Right hinge bracket |
| ⑦ Middle, large part of boiler hood | ⑮ Heat retaining mat |
| ⑧ Rear, small part of boiler hood | |

For a more detailed description of assembly sequence see pages 26 – 31.

The brackets ①, which there are 4 per boiler, are used to support the side walls and sit with their flat faces between the guide rails on the front and rear sections. They are screwed on, from the outside, using hexagon screws, nuts and washers.

First line up brackets longitudinally and crosswise and ensure they are horizontal and then tighten screws. Distance across between brackets, hole to hole is 29".

Now fit front lower transom plate ② screwing it loosely to the front section.

Next screw rear transom plate ③ loosely to the connection. After the side walls have been fitted the transom plate will have to be lined up.

Hang left and right side walls ④ and ⑤, in each case the recess has to fit over the hook on the bracket.

Side walls and transom plate should now be screwed together tightly.

Now place heat retaining mat ⑮ on top of the boiler pulling it forward up to the brackets.

The front small part of the boiler hood ⑥, which supports the control panel, is now fitted between the side walls and screwed tight ($\frac{1}{4}$ " x $\frac{5}{8}$ ").

Now tighten front transom plate ②.

Insert middle upper part of hood ⑦.

Now insert rear upper hood ⑧ and screw to brackets.

Line up rear transom plate ③ and screw tightly to side walls.

Rear lower part of boiler wall ⑨ should now be placed between the side walls and then lifted and hooked into the transom plate.

Rear middle part of boiler wall ⑩ (over the flue header) can now be inserted into the transom plate and screwed to the side walls.

Rear upper part of boiler wall ⑪ is now positioned by pushing its lugs into the middle part and screwed to the side walls.

Now screw in left and right hand hinge bracket ⑬ and ⑭.

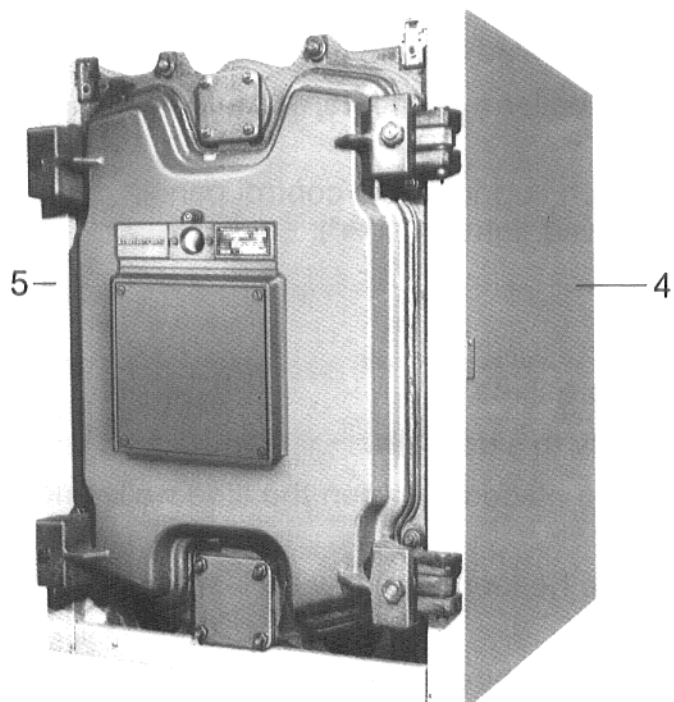
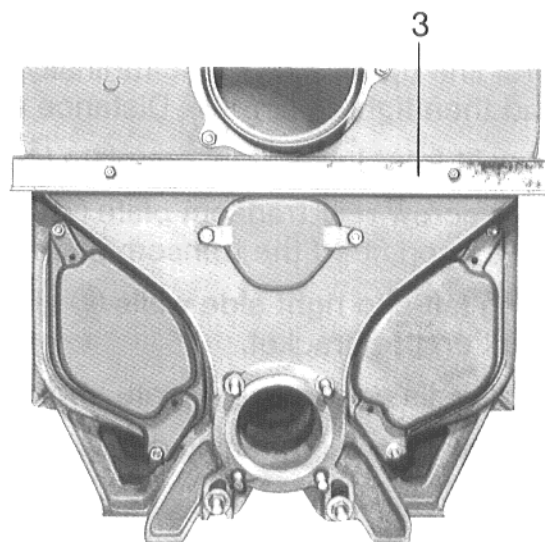
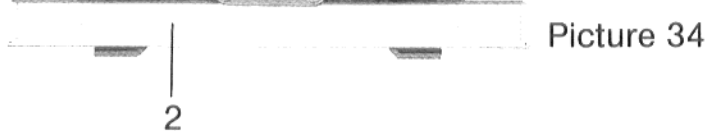
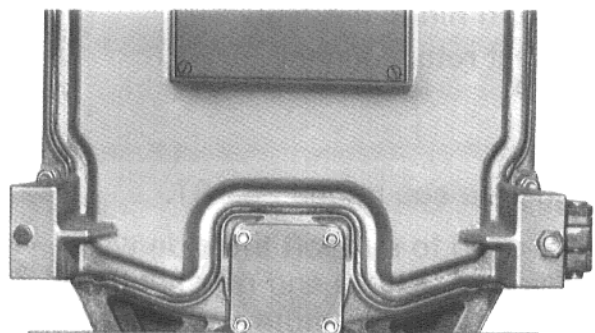
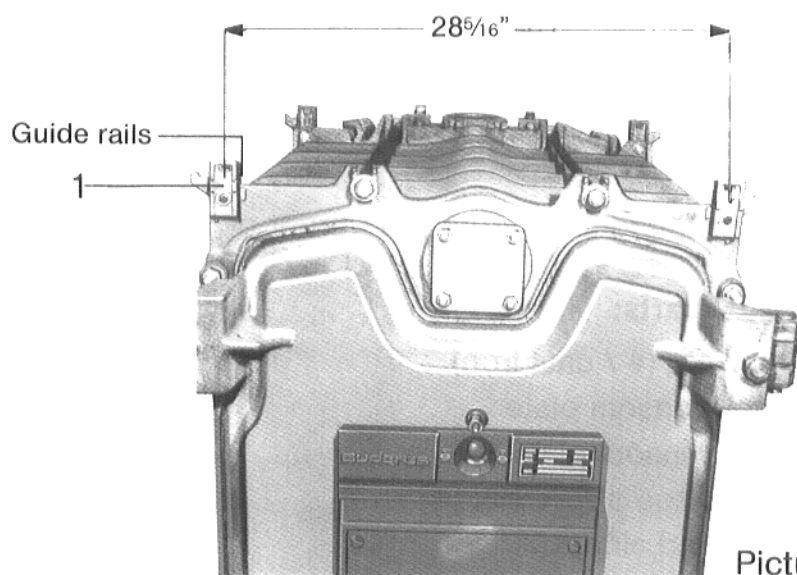

Brackets ①, 4 per boiler casing, are placed with their flat faces, between guide rails on the rear sections and screwed on using screws, nuts and washers.

(Distance across between brackets, hole to hole is $28\frac{3}{8}$ inches)

Loosely screw on front transom plate ②.

Screw on rear transom plate ③.

Hang left and right hand side walls from brackets after these have been lined up ④ and ⑤.

The side walls have to sit close to the hinge bracket resp. to the door closing bracket. See also Picture 24 and 25, Page 18.

Screw side walls tightly to lower transom plate ②.

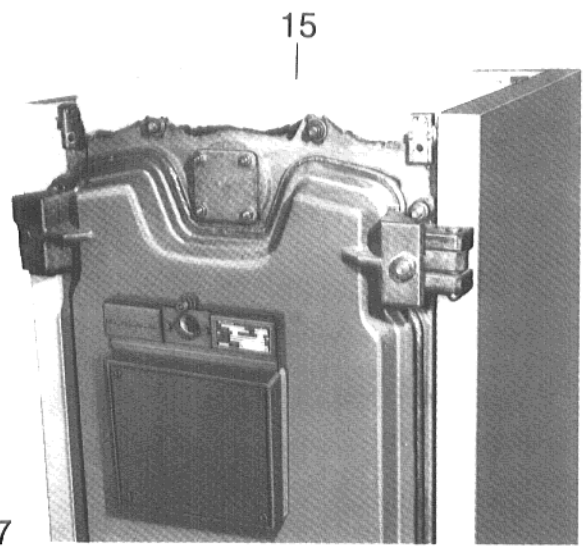

Picture 37

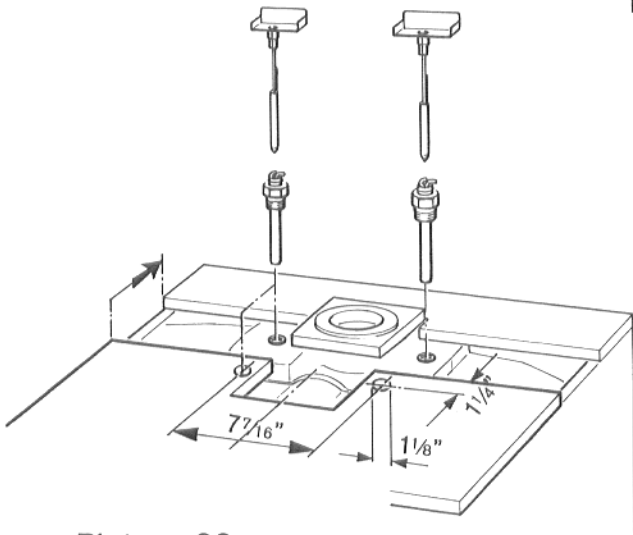

Picture 38 a

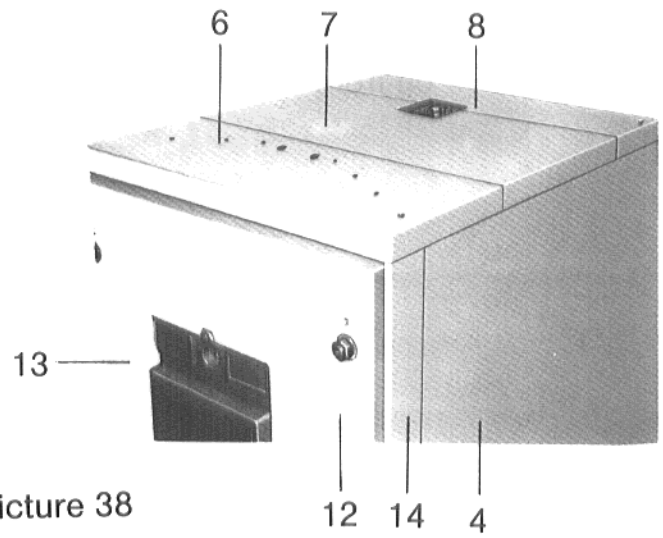

Picture 38

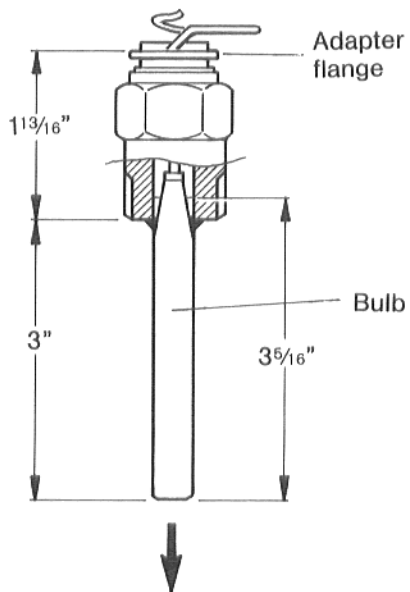

Picture 38 b (3/4" aquastat well)

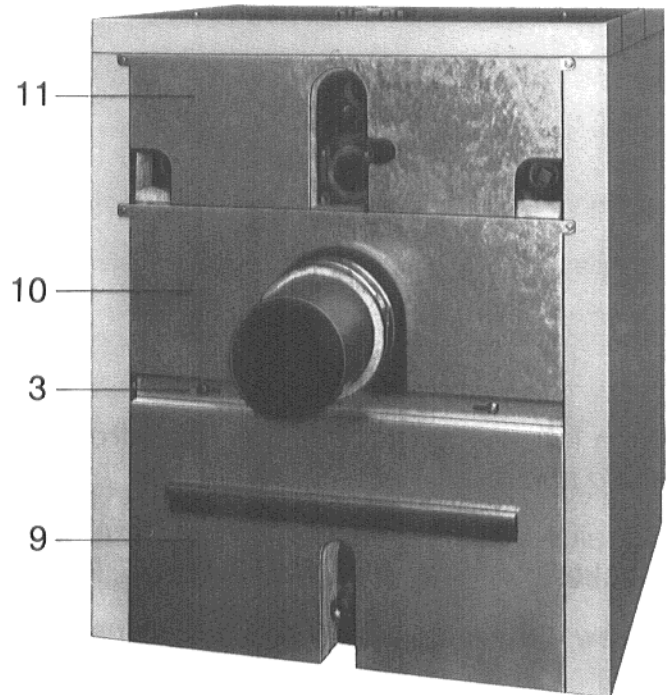

Picture 39

Place thermal insulating mat ⑮ on top of boiler and pull forward up top brackets.

Front small boiler hood ⑥ is placed between side walls and screwed to the upper brackets ($\frac{1}{4}$ " x $\frac{5}{8}$ " with washers).

Cut openings for the thermostats into the middle part of the upper boiler cover ⑦ as per pict. 38.

Tighten well as per pict. 38 a in the rear section.

Middle upper part of hood ⑦ can now be positioned.

Rear upper part of hood ⑧ should now be placed and pushed in.

Line up rear (lower) transom plate ③ and screw to side walls.

Front (lower) transom plate ② can now be screwed on.

Rear (lower) part of side wall ⑨ is positioned between side walls, then lifted and its slots are hooked into the transom plate.

Place rear (middle) part of wall ⑩ (over flue gas header) inside transom plate ③ and screw to side walls.

Insert rear (upper) wall part ⑪ by its lugs into the middle part and screw to side walls.

Screw on left and right hand hinge bracket ⑬ and ⑭.

Screw on burner door cover ⑫.

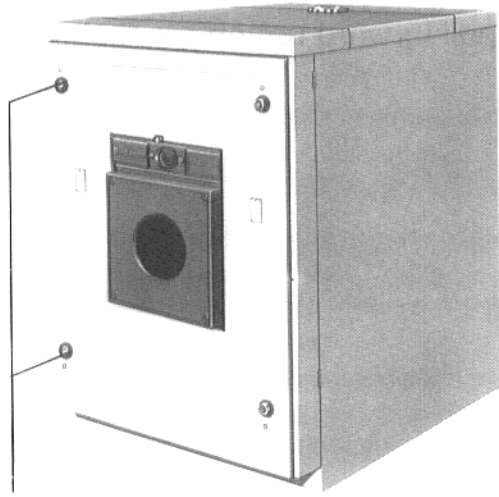

Loosen screw M 5/8" x 1" with the burner door opening to the right

Picture 40 Fix burner door on the left hand side

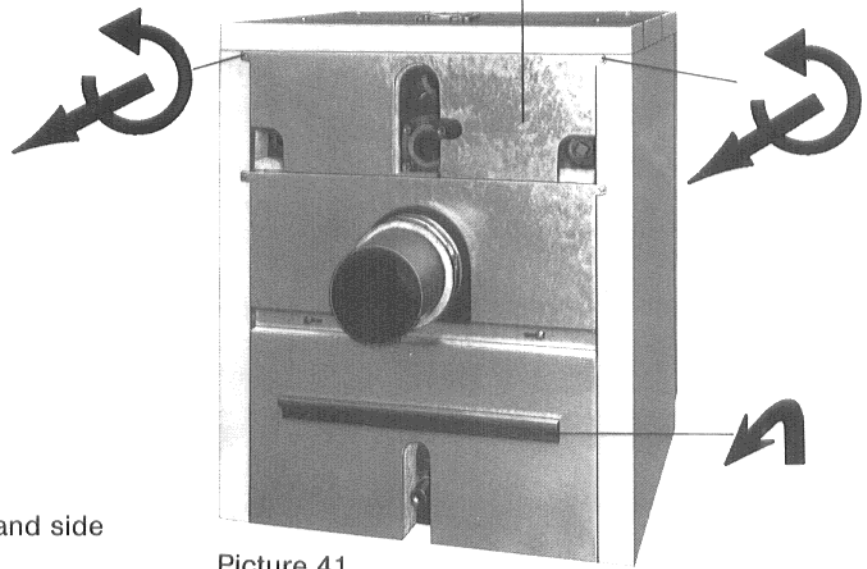

Picture 41

Cleaning covers at the connection section

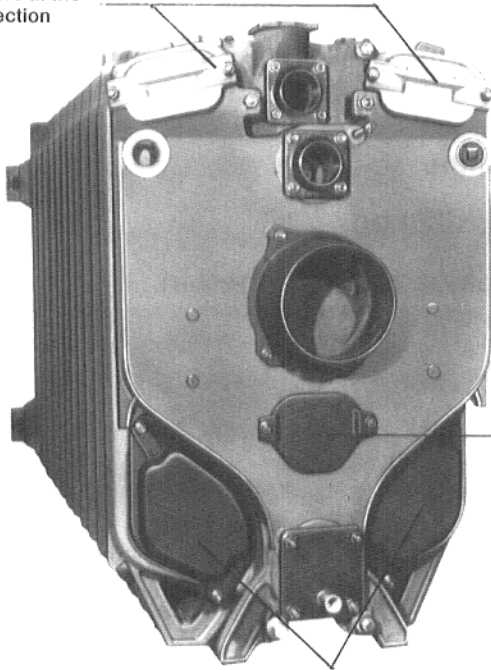

Cleaning cover underneath the flue gas connection

Picture 42

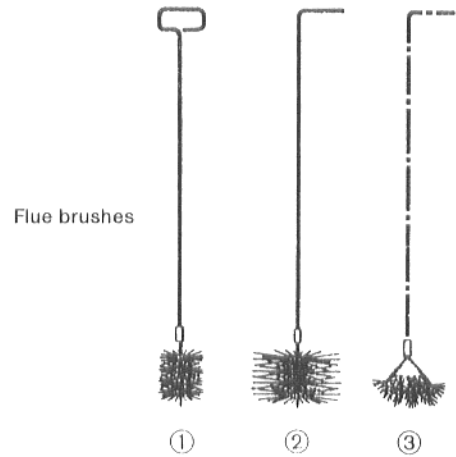

Flue brushes

① ② ③

Picture 43

Flue brush No. ①

Cleaning covers on the right and left hand side on the lower part of the rear section

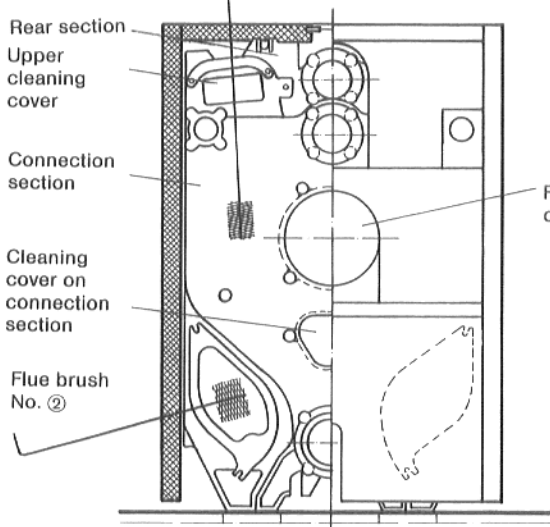

Picture 44

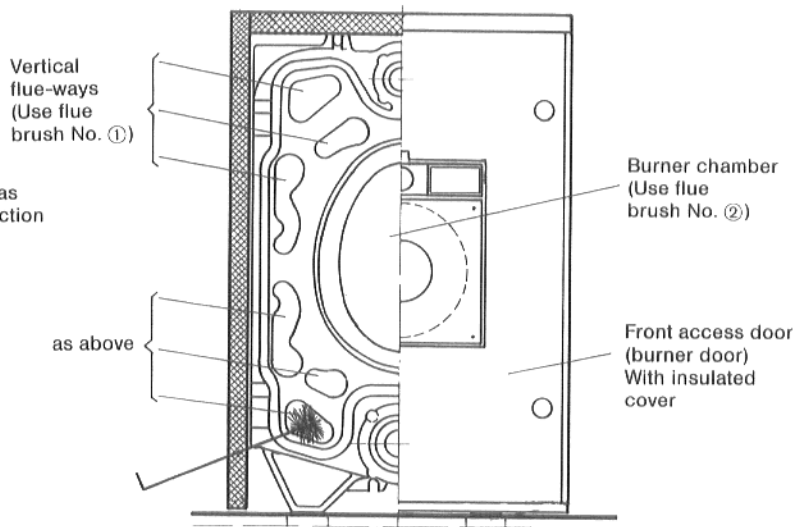

Picture 45

9. Cleaning and maintenance

Cleaning brushes

Optional cleaning brushes are available from Buderus Hydronic Systems.

Annual inspection

To ensure trouble-free and correct operation, the burner installation should be checked by an expert at least once per year. The correct functioning of the entire installation should be verified at that time, and immediate repairs arranged if any faults are found. The boiler should be checked at regular intervals for heating-gas side leaktightness. It is particularly important that all seals and sealing cords on the cleaning covers are still sound, and to replace them if necessary.

Water level check

The operator must ensure that the boiler is correctly filled. All pipes, radiators and boiler must be water tight and valves and controls should be correctly set. The entire system must be vented at all available points.

Make-up water

For initial filling, the hardness should not exceed 12 GPG. If frequent make up water is required water should be softened.

Mechanical Cleaning

- Cut off electricity and combustible supply.
- Open burner door.
Remove both hexagon screw M $\frac{5}{8}$ " x $3\frac{15}{16}$ ", left if hinged on right and right if hinged on left hand side (Picture 40).
- Unscrew upper rear jacket panel (Picture 41) from side panels and lift off.
- Unscrew lower rear jacket panel from side panels and pull off downward.
- Unscrew cleaning cover at the upper part on the connection section (Picture 42).
- Unscrew cleaning covers on the left and right hand side at the lower part of the rear section (Picture 42).
- Open cleaning cover underneath the flue gas connection (Picture 42).
- Introduce cleaning brush ① into the cleaning opening at the upper part of the connection section and brush the vertical flue gas channels upwards and downwards (Picture 44). Eliminate soot thru the cleaning opening beneath the flue gas connection.
- Also brush the different horizontal and vertical flue gas channels with cleaning brush ① towards the rear (Picture 45). Start at the top and eliminate soot thru the cleaning openings on the left and right hand side of the rear section (Picture 44).
- Clean with brush ② around openings on the left and right hand side at the lower part of the rear section.
- Also clean the combustion chamber with brush ② and take off soot towards the front.
- Brush rear wall of the combustion chamber with brush ③ (fix it on handle ②) and clean towards the front.

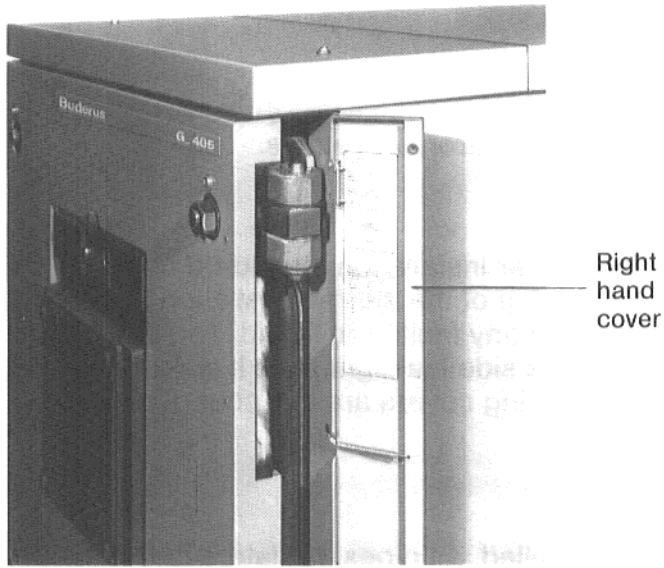

Picture 46 shows burner door opening to the left

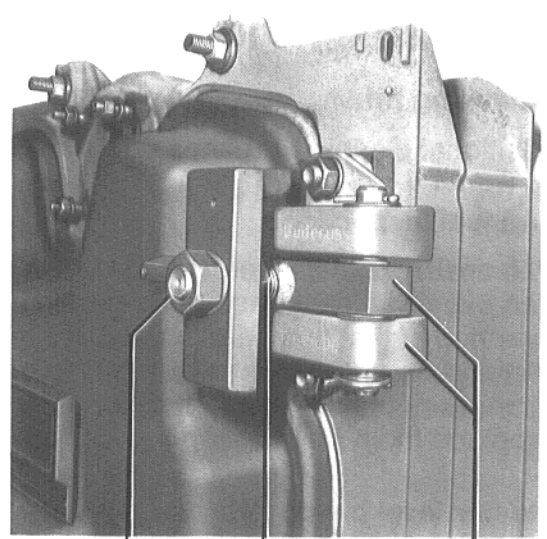

Picture 47 hinge on a door opening to the left

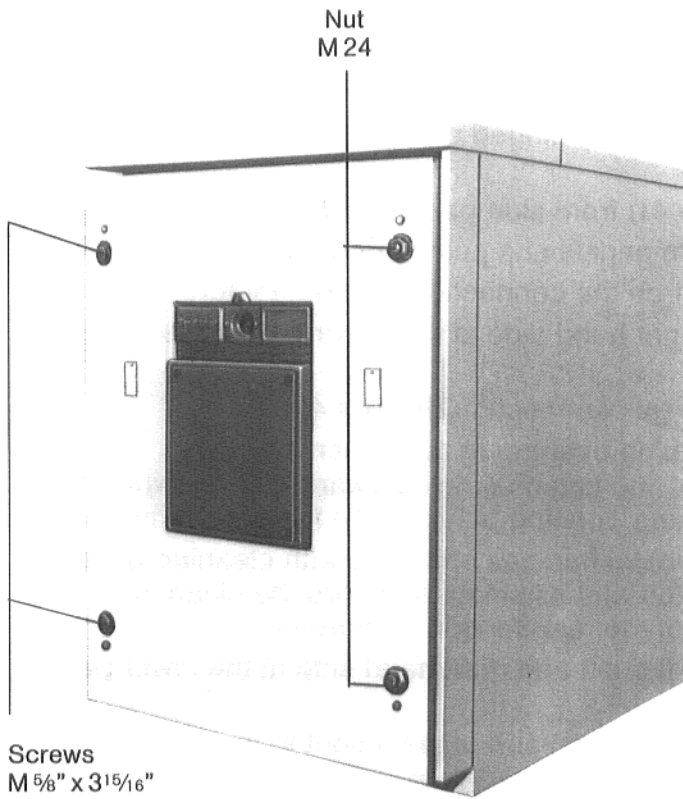

Picture 48 shows burner door opening to the left

- Check seals and sealing ropes of the cleaning covers and the burner door.
- Close cleaning openings tightly.

Close burner door.

- With burner door opening to the left, open right hand cover (Picture 46).
With burner door opening to the right, open left hand cover correspondingly.
- Loosen flat nut M 24 (Picture 47) on the inside at the hinge (upper and lower one) a few turns.
- Swing burner door while lifting it at the same time and screw in the upper and lower hexagonal screws M $\frac{5}{8}$ " x 4" partly. With the door opening to the right hand side, screw in on the other side.
Fasten the two screws M 16 x 100 and the nuts M 24 crosswise (Picture 48).
- Fasten the above mentioned flat nut M 24 tightly with the hinge (Picture 47).

Wet cleaning

Wet cleaning should be carried out in the same order as mechanical cleaning, described above. It is, however, important to carefully study the manufacturer's instructions for the cleaning compounds and cleaning tools used for this purpose.

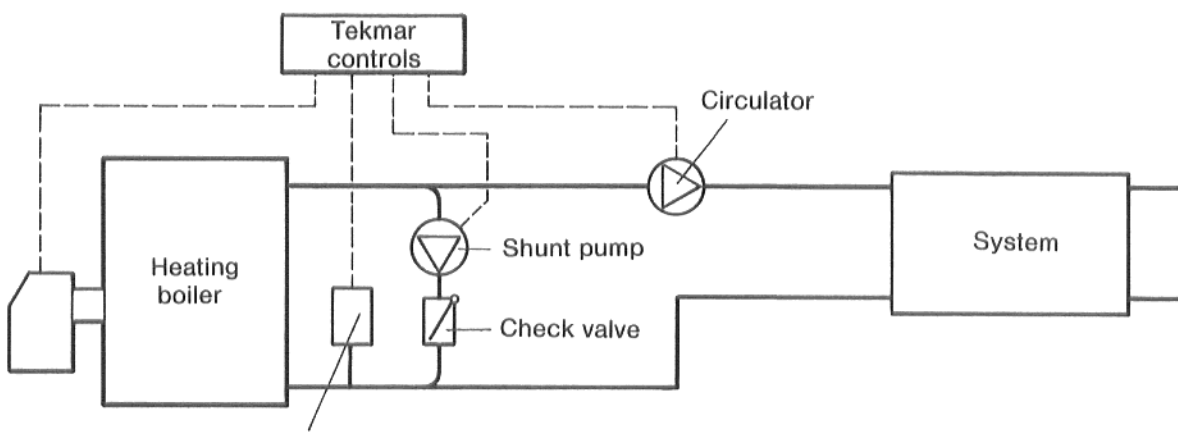

Picture 49 Temperature sensor

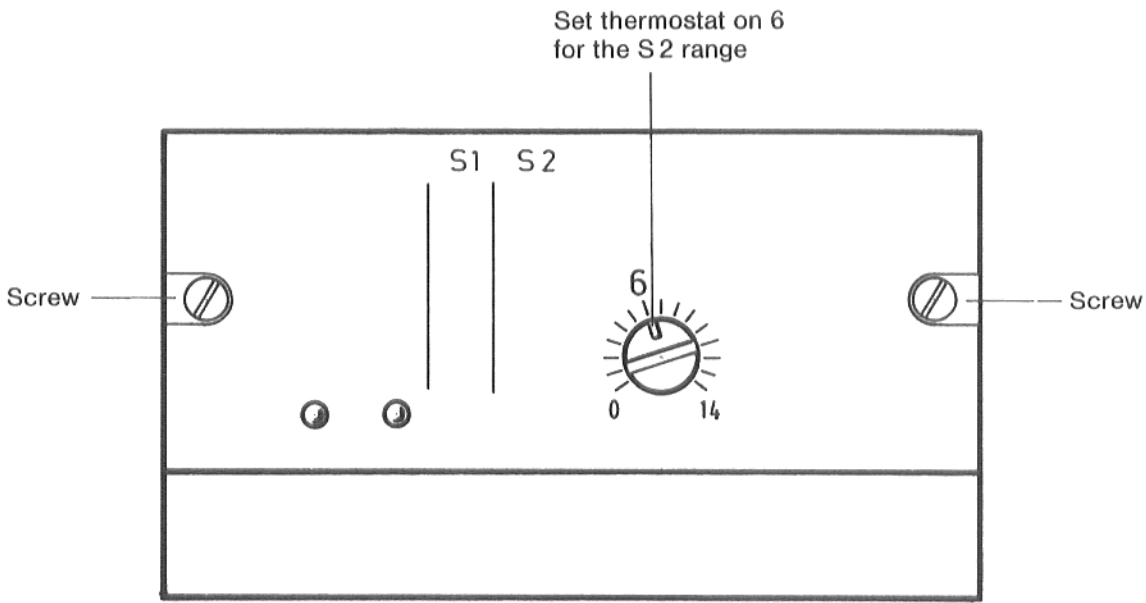

Picture 50 Front side: "tekmar On/Off, Setpoint Control type 226"

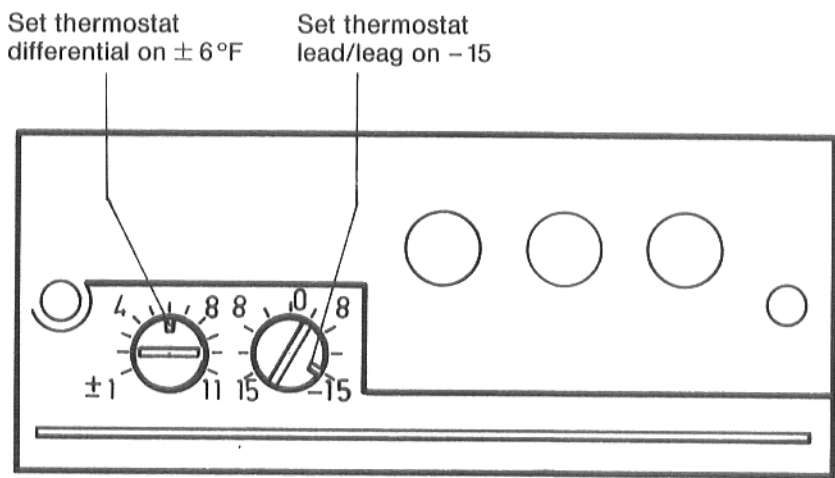

Picture 51 Back view without base: "tekmar On/Off Setpoint Control type 226"

10. Control of the return temperature

For schematics of a boilerwater return control with a Tekmar on/off setpoint type 226 revert to picture 49.

For the boiler series G_505 connect set the Tekmar control, type 226 as follows:

- Set thermostat on 6 as shown in picture 50.
- **Unscrew both screws** and take controls off their base (Picture 50).
- **Set thermostat differential on** $\pm 6^{\circ}\text{F}$, on the rear of the controls (Picture 51).
- Set the control **lead/leag on** - 15 on the rear of the controls (Picture 51).
- Set controls back on their base and fasten with **screws** (Picture 50).
- Connect temperature **sensor to the connections** $\overset{13}{\text{CS}}$ and $\overset{12}{\text{S2}}$ to assure that measurements will be taken in the high range = S2-range.
- For further electrical connecting revert to control producer's instructions.

Boiler installed by: _____
(contractors adress)

Boiler installed on: _____
(date of installation)

Buderus Hydronic Systems
52 Washington Street
P. O. Box 1279
Auburn, N. Y. 13021
Phone (315) 252-3723 · Fax (315) 252-6772

In the interest of technical progress we reserve the right to alter or improve our production items without prior notice.
Printed in Germany