

3. 1 1/4" screw-in (Fig. 3)
 TBS-Isocal SEN/SED 140 - 600 and
 ST/H/B/R 200 - 600:

Sequence of steps:

1. Remove the top cover and insulation from the domestic hot water tank.
2. Disconnect ground cable from magnesium anode.
3. Unscrew magnesium anode.
4. Seal in end of replacement anode using Tellon tape.
5. Reconnect ground cable.
6. Check for tightness.
7. Replace insulation and the tank cover.

Note:

It is also possible to remove the hand access cover and then replace the anode. The gasket for the hand access cover should be inspected whenever the hand access cover is removed and replaced if necessary .

4. M8 threaded stem with counter nut (Fig. 4)
 TBS-Isocal ST/SE/SF/TT/LT:

Sequence of steps:

1. Remove the top cover and insulation from the domestic hot water tank.
2. Disconnect ground cable from magnesium anode.
3. Unscrew nuts of hand access cover.
4. Remove hand access cover complete with anode.
5. Discard used anode and replace with new anode (Fig. 4).

Important: Remember to use insulating sleeve and seal.

6. Replace gasket of hand access cover if required.
7. Replace hand access cover with anode and screw down.

Important: Tighten nuts by hand and then tighten further using a torque wrench (30 ft - lb. corresponds to approx. 3/4 turns with a wrench).

8. Reconnect ground cable.
9. Check for tightness.
10. Replace insulation and the tank cover.

5. 1 1/4" male thread with locking nut (Fig. 5 and 6),
 TBS-Isocal LN..350 - 4000 and
 SN..350 - 3000:

Sequence of steps:

1. Remove the front panel or top cover from the domestic hot water tank.
2. Remove thermal insulation.
3. Remove manhole cover.
4. Disconnect ground cable from magnesium anode.
5. Hold anode reaching through manhole and unscrew nut.
6. Remove anode through manhole.
7. Install replacement anode in reverse order.
8. Replace gasket of manhole cover as necessary and screw down lid.
9. Reconnect ground cable.
10. Check for tightness.
11. Replace insulation.
12. Replace tank front panel or top cover.

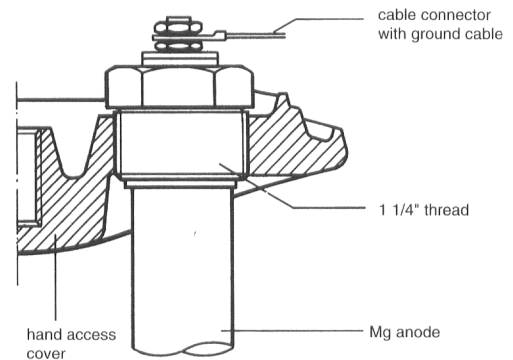

Fig. 3

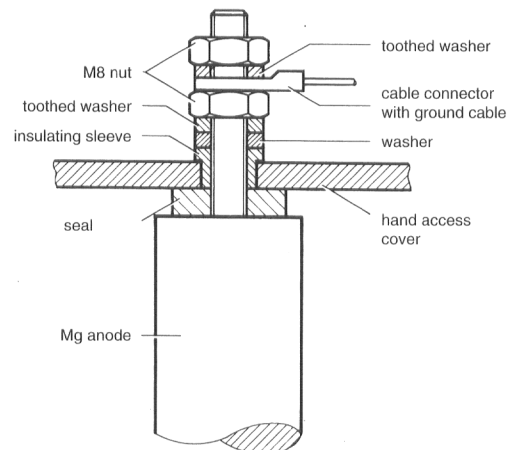

Fig. 4

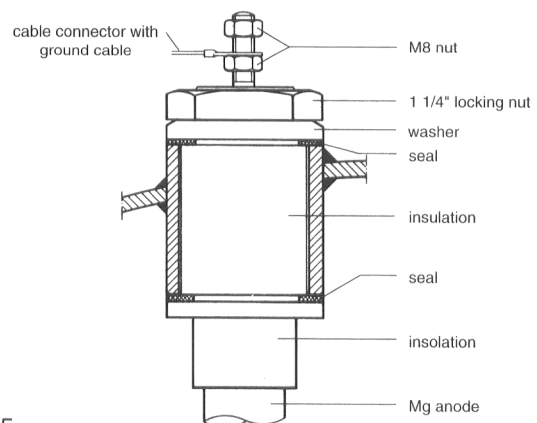

Fig. 5

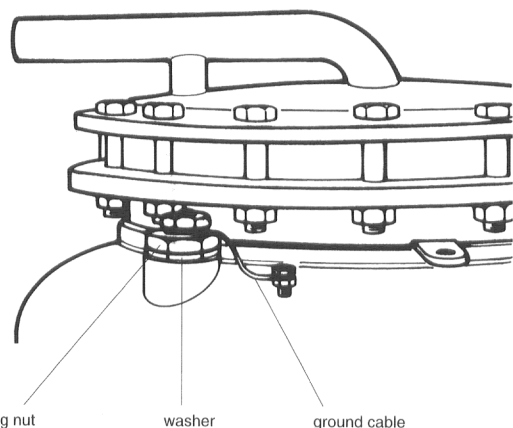

Fig. 6